



SURFACES
GRAPHIC
INSTALLATIONS
ARTWERKS

Pintark

CRAFTING
BEAUTIFUL
surfaces



Pintark
IS POSSIBILITIES.

An architectural solutions brand specialising in advanced surface treatment and crafted material application.

Created for interiors and furniture application, Pintark's product and techniques are available in multiple combinations of materials and finishes.

Applied over numerous suggested tiles, blocks and weaves, Pintark's adaptable system creates personal distinction in every surface.

Inherent to Pintark's bespoke solutions is the brand's ability to offer crafted distinction.

Alongside an evolving portfolio of materials and finishes, and the brand's dedication to creating refined surfaces, Pintark offers a complete service delivering bespoke design and a range of traditional crafting techniques. Enhancing textural complexity and visual experience.

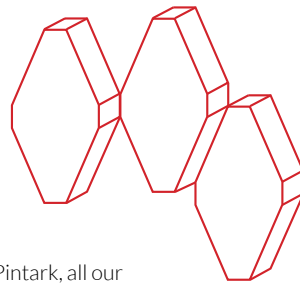

At Pintark, all our product & techniques are developed and produced in-house, giving the brand full control over the product it offers

PATTERNS.

Perus. *Pg 20*

Aden
Bruges
Delta
Detroit
Foliage
Grain
Jura
Lida
Tula
Valencia
Valencia Straight
Versaille
York

Marque. *Pg 56*

Artem
Chicago
Cuboid
Cuboid Insert
Dominion
Fishscale
Fluted
Harlem
Ion
Lima
Montgomery

New Mexico
Pisco
Porto
Shanghai
Taza
Taiz
Tokyo
Tokyo Mini
Truno
Westminster

Isa. *Pg 118*

Battersea
Dara
Edin
Fez
Fiore
Lattice
Lisson
Montane
Turin
Verona

SYSTEMS.

Manhattan. *Pg 148*

Honeycomb
Leather
Veneer

GRAPHIC
INSTALLATIONS &
ARTWERKS

Graphic Installations. *Pg 162*

Fulcrum

Inflight

Pixa

Artwerks. *Pg 174*

Citylights

Fracta

Fossil

Kaeisol

Transa

Uber Bang ::

Textile Artwerks. *Pg 202*

Perla

Perla Circle

Lakeer

Phool

Shaher:City

Floret

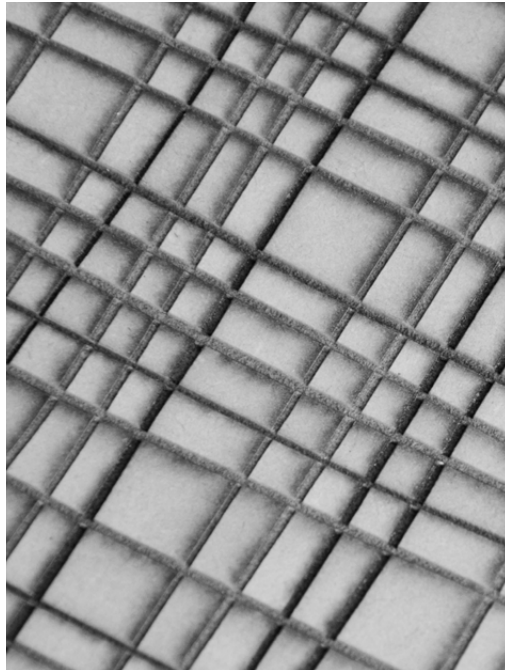

Pintark

PATTERNS.

At Pintark we believe in innovating the use of our products.

Our in-house patterns are all-in-one design solutions that can be used as is or personalised with tailored material and finish selections.

Pintark patterns employ our tiles, blocks and weaves, aimed at offering customers a broad range of ready made designs that are suited to a range of interiors and styles.

perus.

*patterns comprising of
a single tile or block*

Perus surfaces are discreet in style - using classic compositions layered with an additional technique or made distinct through the use of material and finish.

A range of component sizes allows for the composition to be scaled up or down, offering an adaptable system that can create an extensive range of compositions and surface designs.

Perus surfaces are ideal for enhancement of feature interior elements such as doors, headboards, ceilings, wardrobes and cabinetry.

aden

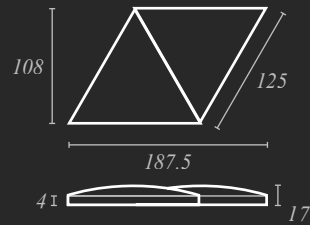

PATTERN REPEAT

187.5 x 108 mm

7.25 x 4.25 inch

MATERIAL

Leathers - Herringbone, Stormy Hammered Silver
Brighton, Pewter*

COMPONENT

Tile - Triangle Padded

Refer to our material catalogues for material/finish options

*Commissioned leather



bruges

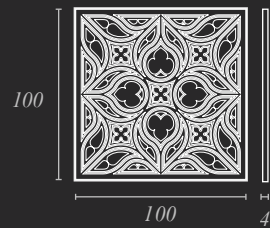

PATTERN REPEAT

100 x 100 mm

4 x 4 inch

TECHNIQUE

Embossing: Motif - EM Gothique

MATERIAL

Leather - Crunch, Tan

COMPONENT

Tile - Square Flat

Refer to our material catalogues for material/finish options

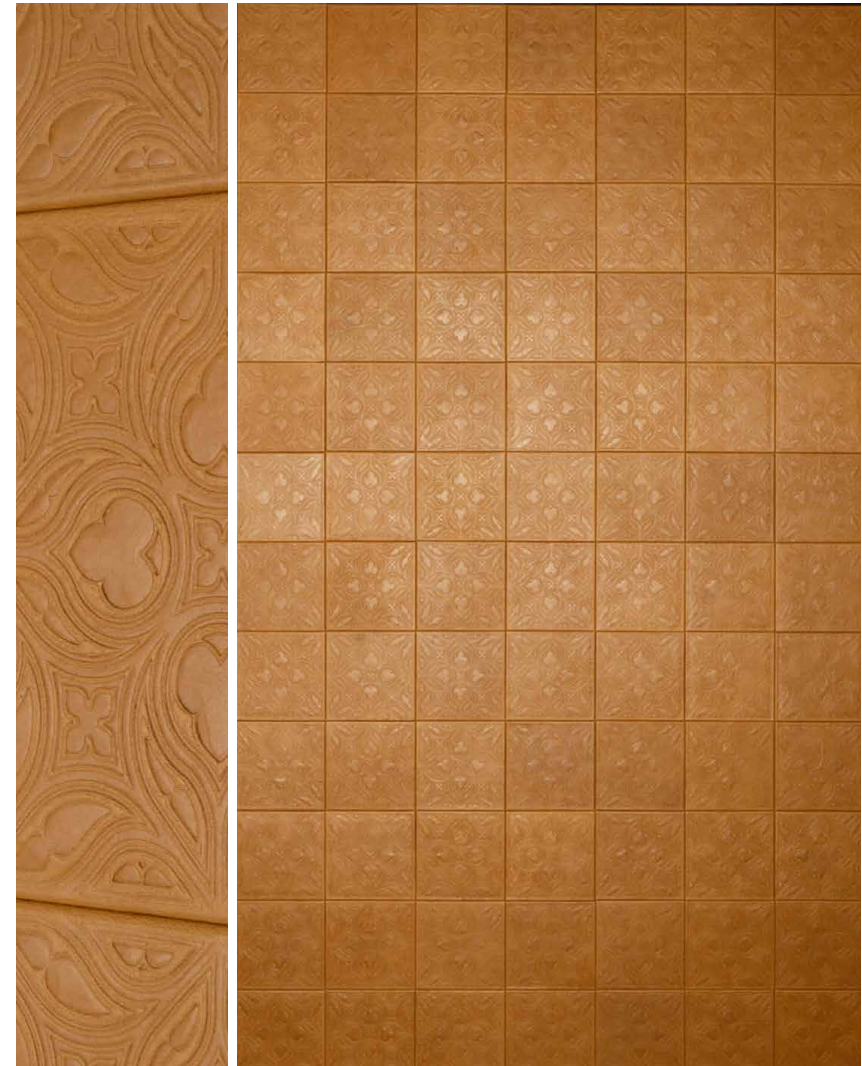

delta

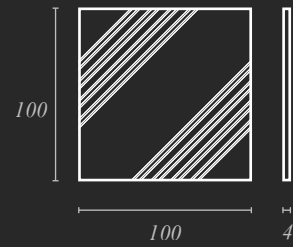

PATTERN REPEAT

100 x 100 mm

4 x 4 inch

TECHNIQUE

Embossing: Motif - EM Stria

MATERIAL

Leather - Old Fashion, Oceano

COMPONENT

Tile - Square Flat

Refer to our material catalogues for material/finish options

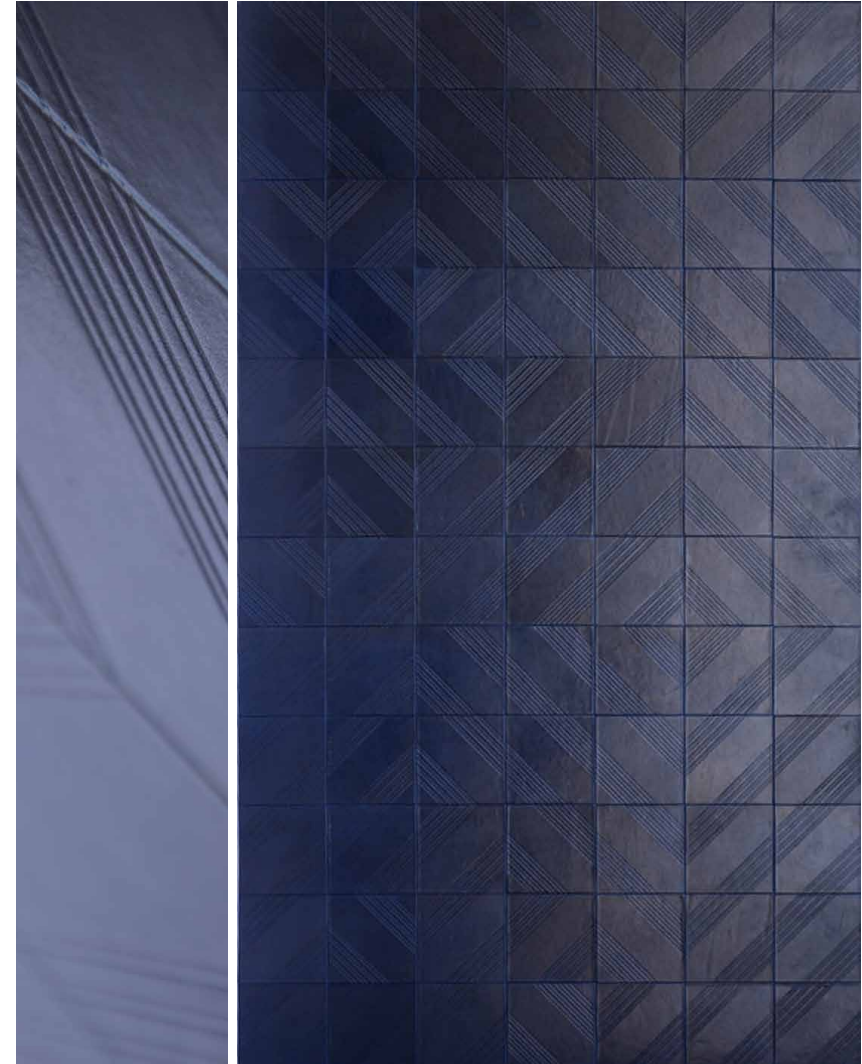

detroit

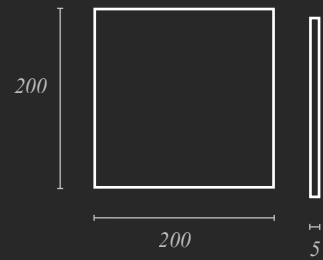

PATTERN REPEAT

200 x 200 mm

8 x 8 inch

TECHNIQUE

Engraving: Motif - EN Bina

MATERIAL

Leather - Hair On, Black

COMPONENT

Tile - Square Flat

Refer to our material catalogues for material/finish options

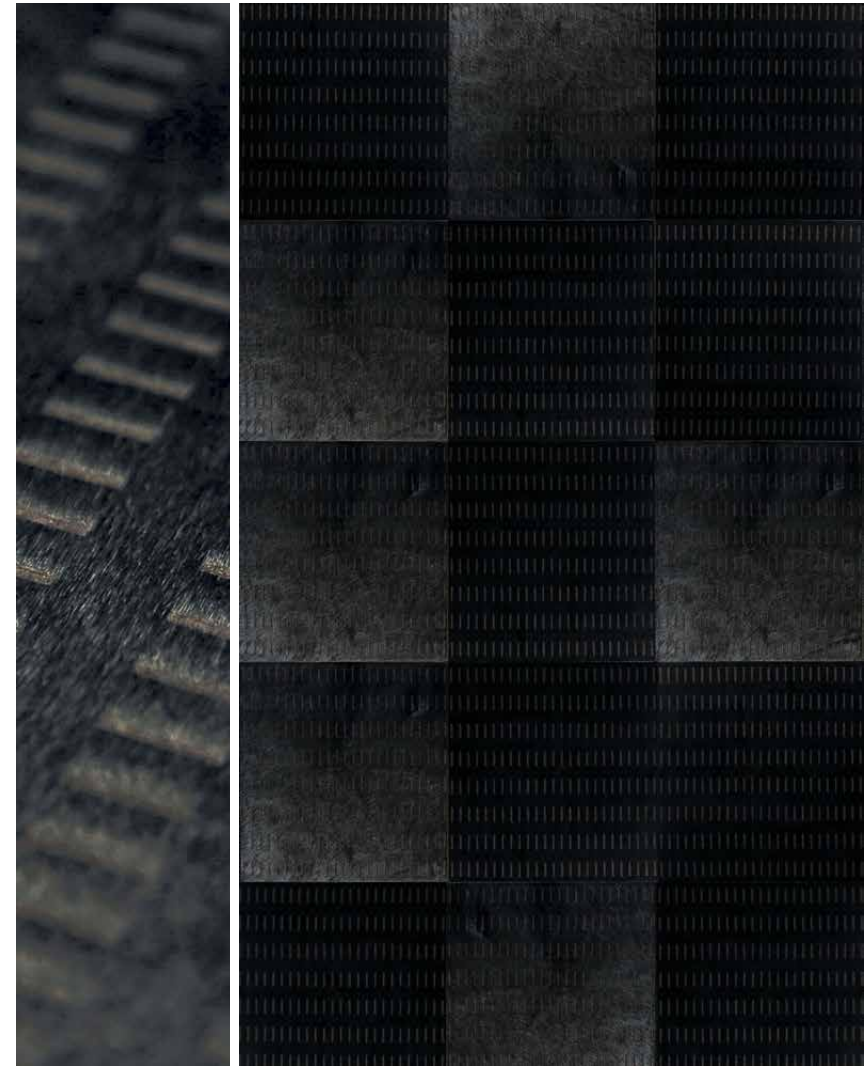



foliage

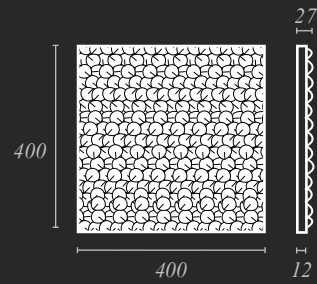

PATTERN REPEAT

400 x 400 mm
16 x 16 inch

TECHNIQUE

Free Form

MATERIAL

Leather - Classic Supple, Brown
Metal - Medium Brushed Antique Finish, on Brass

COMPONENT

Tile - Square Flat

Refer to our material catalogues for material/finish options



foliage
application

FEATURE HEADBOARD



grain

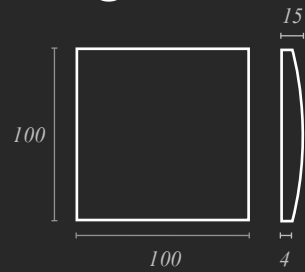

PATTERN REPEAT

100 x 100 mm
4 x 4 inch

TECHNIQUE

Embossing: Motif - EM Mesquite

MATERIAL

Leather - Classic Soft, Beige

COMPONENT

Tile - Square Padded

Refer to our material catalogues for material/finish options

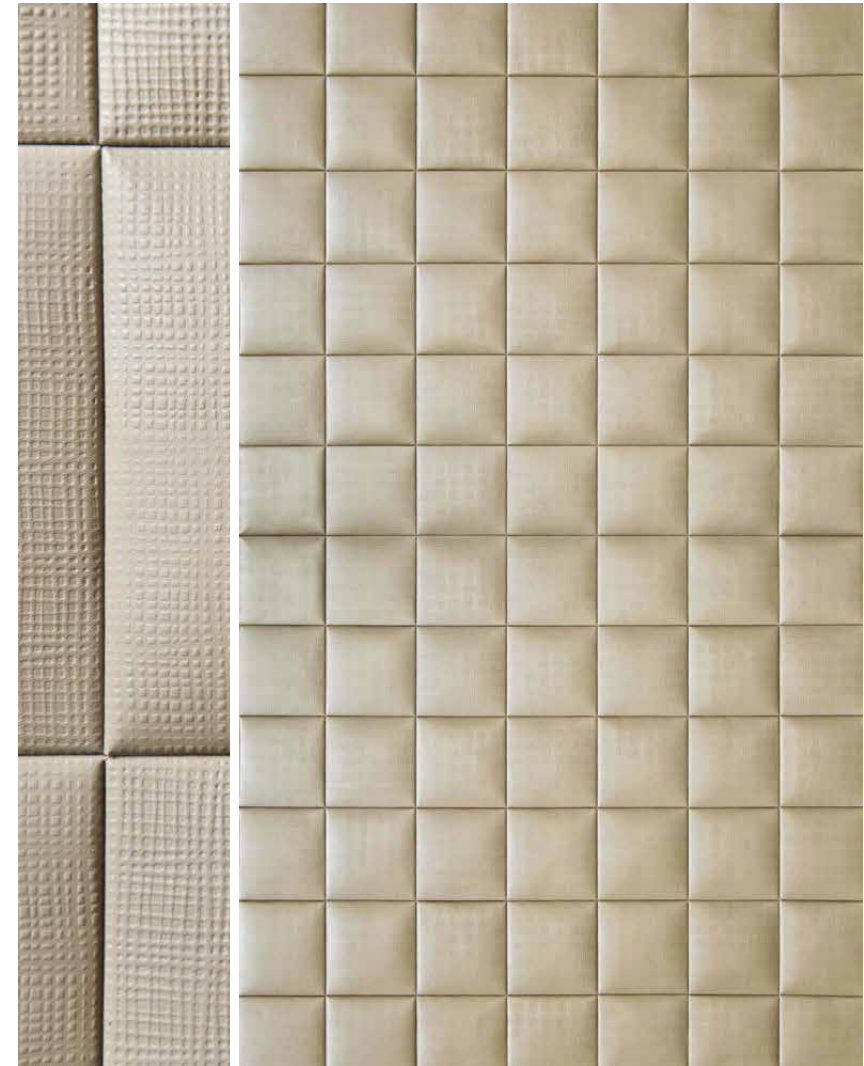

jura

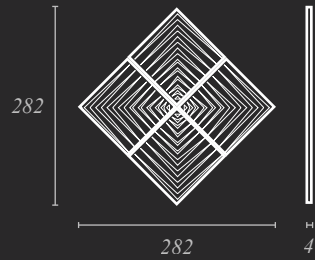

PATTERN REPEAT

282 x 282 mm
11 x 11 inch

TECHNIQUE

Tech Cut: Motif - TC Serrate

MATERIAL

Leather - Classic Soft, Brown
Fabric - Ultra Suede, Brown

COMPONENT

Tile - Square Flat

Refer to our material catalogues for material/finish options



lida

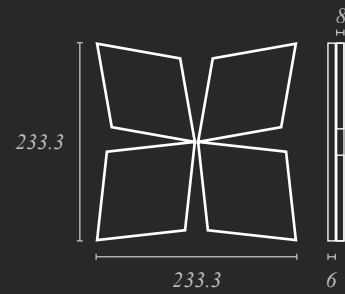

PATTERN REPEAT

233.3 x 233.3 mm

9 x 9 inch

MATERIAL

Leather - Crunch, Tan
Fabric - Ultra Suede, Brown

COMPONENT

Tile - Rhombus Flat

Refer to our material catalogues for material/finish options

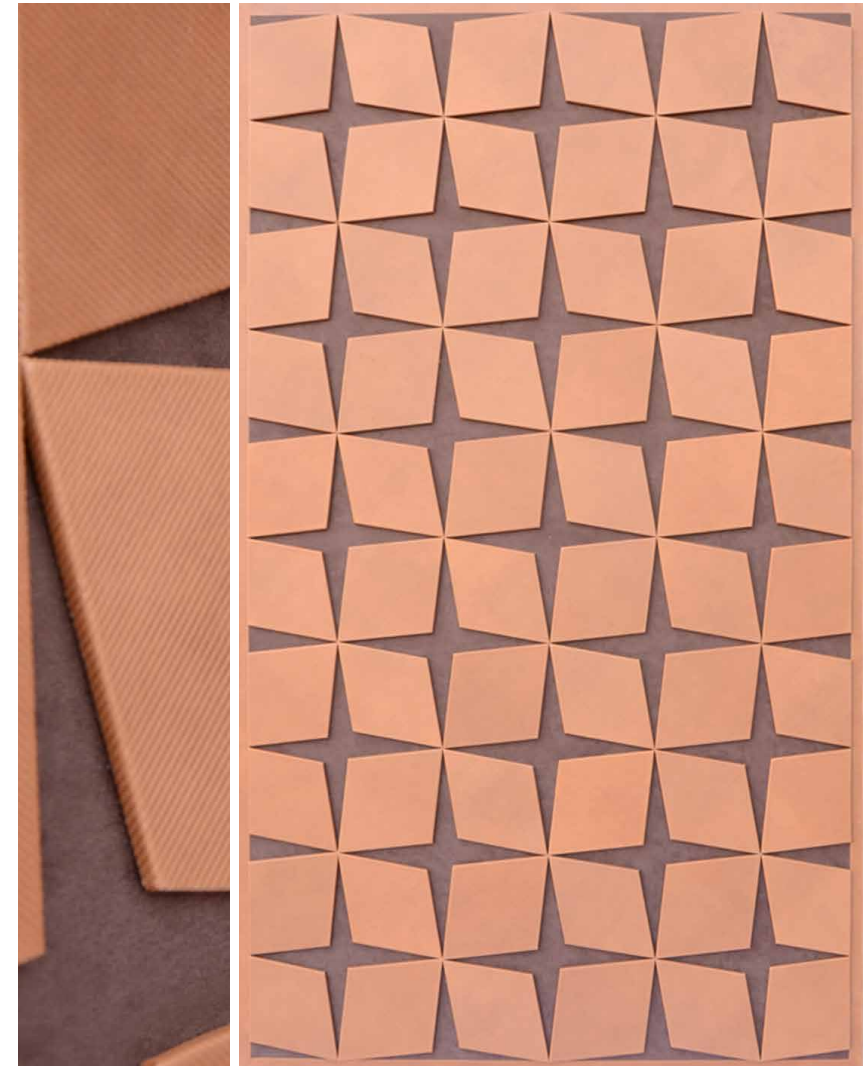

tula

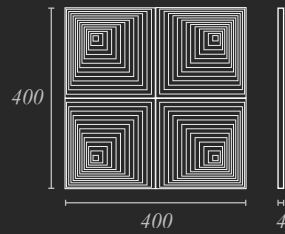

PATTERN REPEAT

400 x 400 mm
16 x 16 inch

TECHNIQUE

Embossing: Motif - EN Spira

MATERIAL

Leather - Old Fashion, Miele

COMPONENT

Tile - Square Flat

Refer to our material catalogues for material/finish options

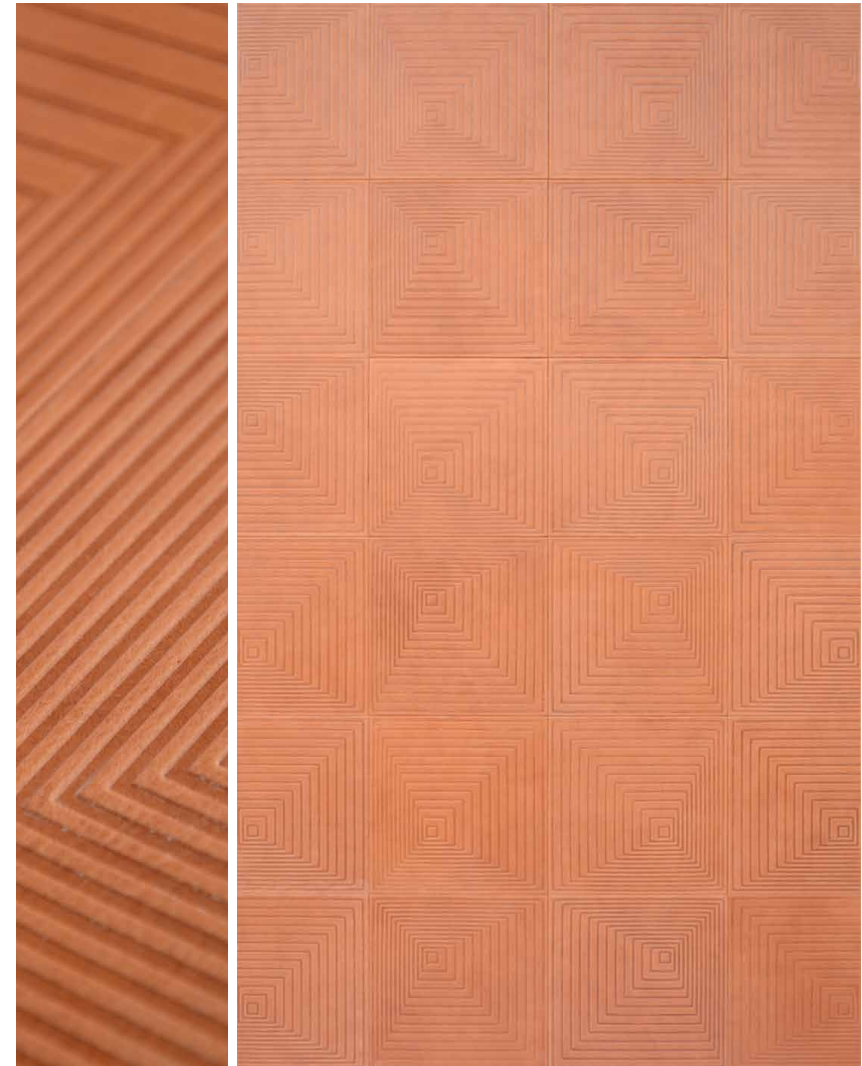

valencia

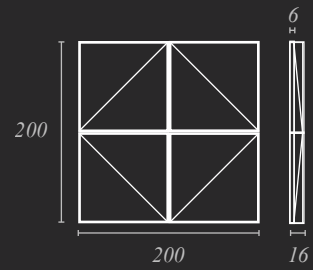

PATTERN REPEAT

200 x 200 mm

8 x 8 inch

MATERIAL

Leather - Crunch, Ox Blood

COMPONENT

Block - Square Double Taper

Refer to our material catalogues for material/finish options

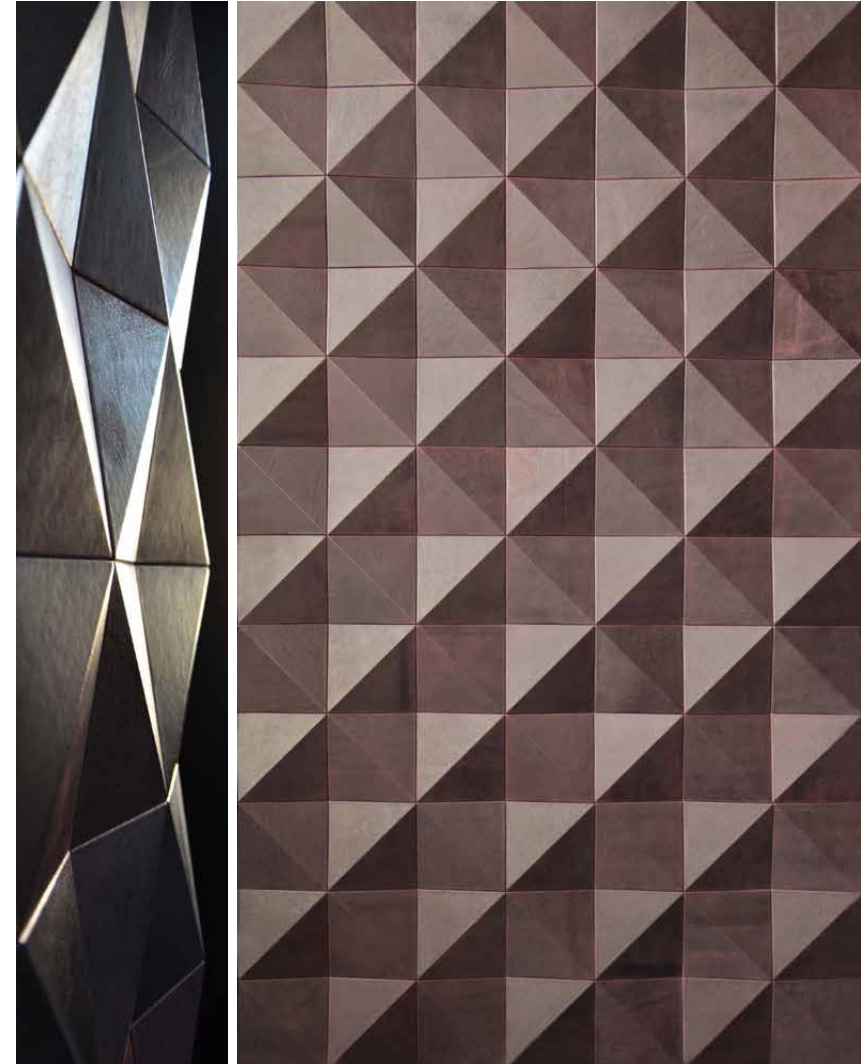

valencia

application

FEATURE DOOR



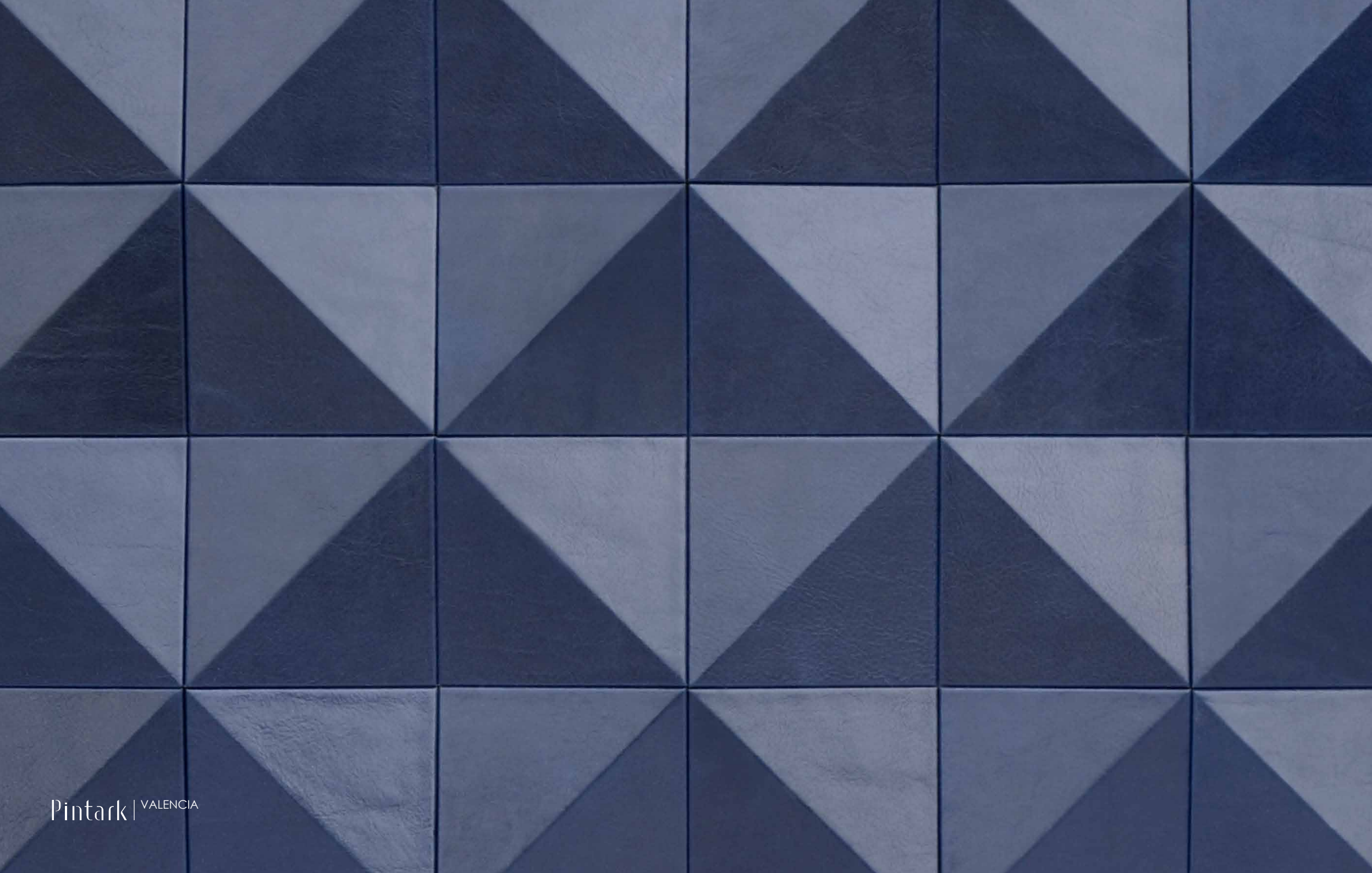

valencia straight

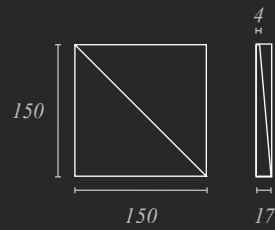

PATTERN REPEAT

150 x 150 mm

6 x 6 inch

MATERIAL

Leather - Crunch, Clay

COMPONENT

Block - Square Double Taper

Refer to our material catalogues for material/finish options

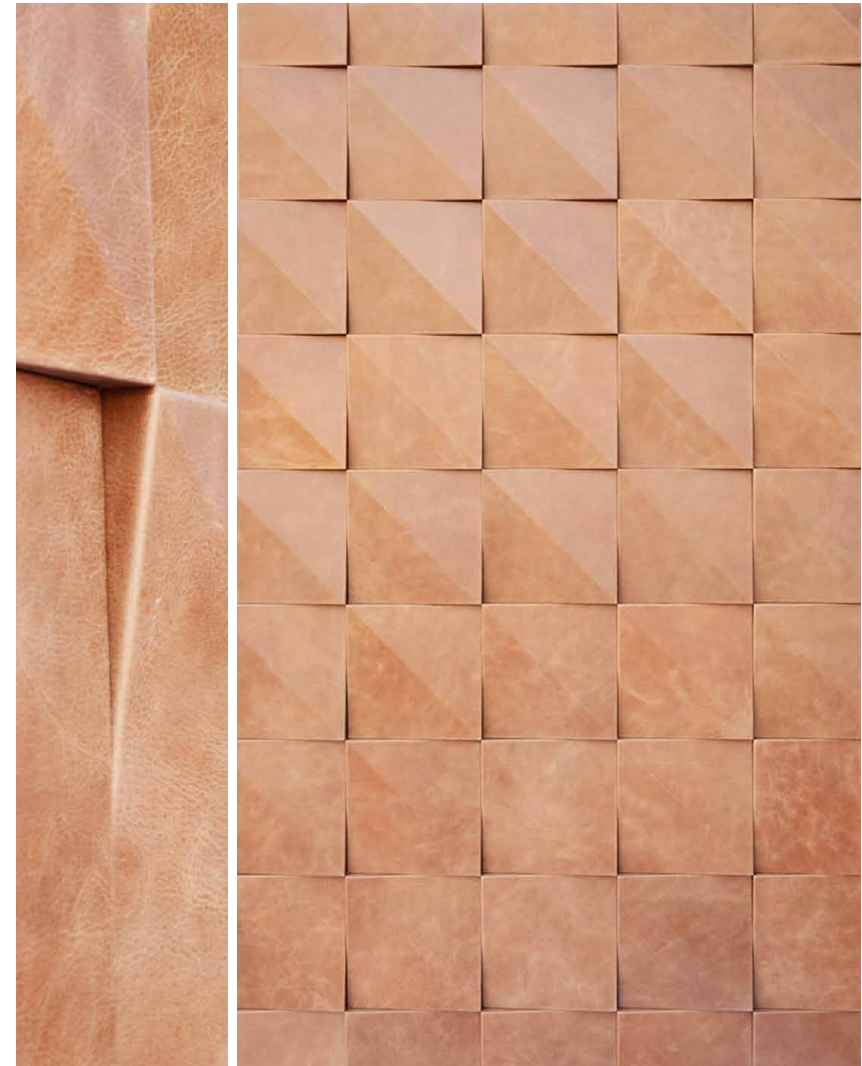

versaille

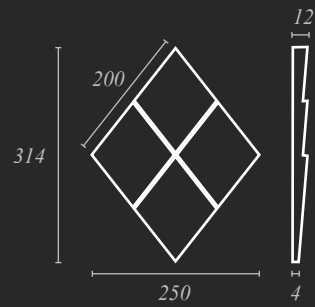

PATTERN REPEAT

250 x 314 mm
10 x 12.25 inch

TECHNIQUE

Embossing: Motif - EM Cord

MATERIAL

Leather - Marine Rich, Black

COMPONENT

Block - Rhombus Taper

Refer to our material catalogues for material/finish options

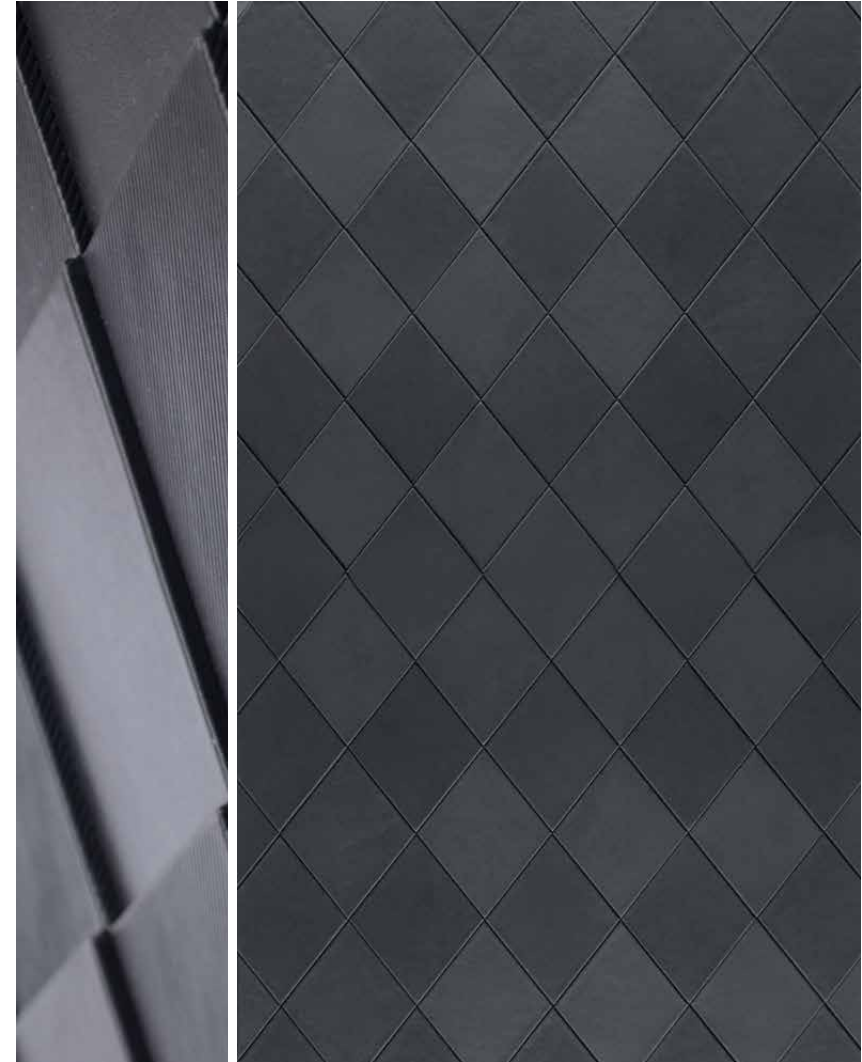

york

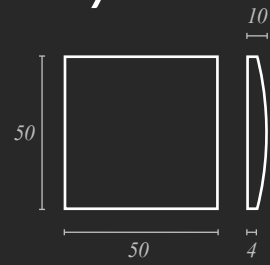

PATTERN REPEAT

50 x 50 mm
2 x 2 inch

MATERIAL

Leather - Crunch, Brown

COMPONENT

Tile - Square Padded

Refer to our material catalogues for material/finish options

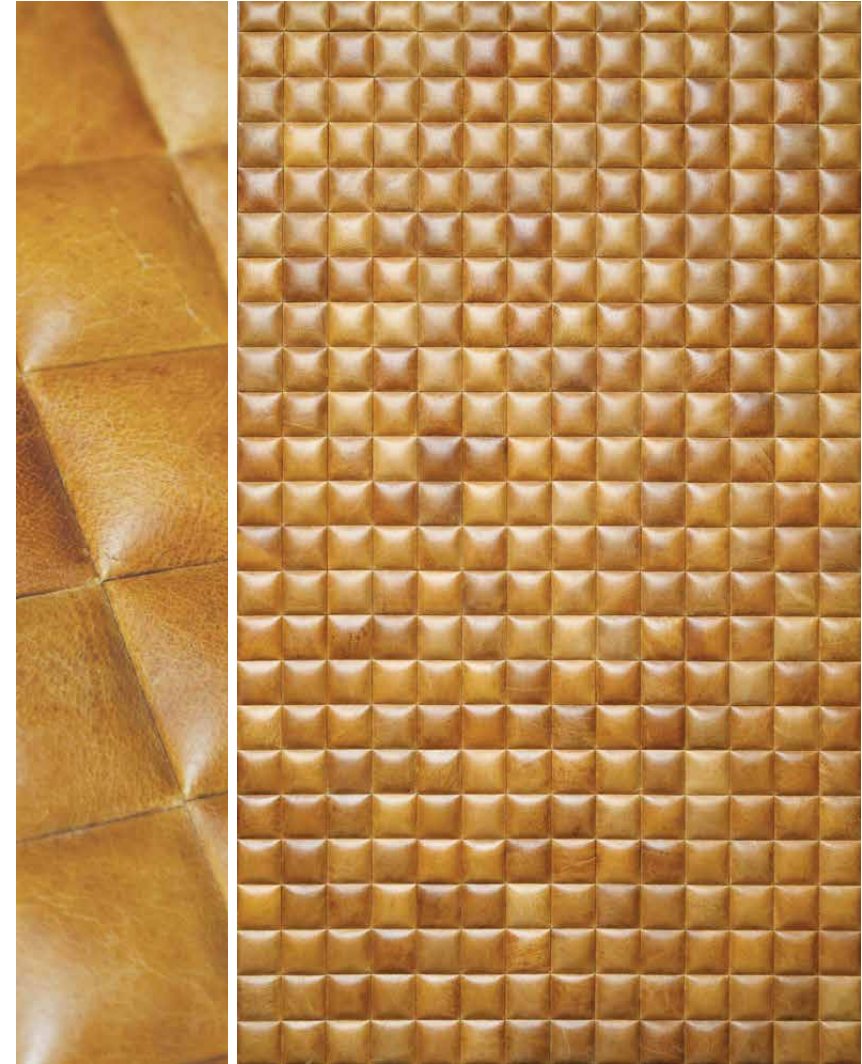

marque.

*patterns employing
combinations of tiles
and/or blocks*

Ideal for larger feature coverages, Marque surfaces comprise of combinations of components and materials creating visually complex compositions.

Reinvented through personal material specification, Marque surfaces are easy to specify through the use of large format pattern repeats.

Marque surfaces are ideally suited to interior enhancement such as feature walls, furniture, large coverages, doors and shutter fronts.

artem

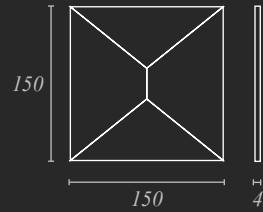

PATTERN REPEAT

150 x 150 mm
6 x 6 inch

TECHNIQUE

Embossing: Motif - EM Cord

MATERIAL

Leather - Old Fashion, Castagna
Metal - Brushed Dark Antique Finish, on Brass

COMPONENT

Tiles - Triangle Flat, Triangle Cut Flat

Refer to our material catalogues for material/finish options

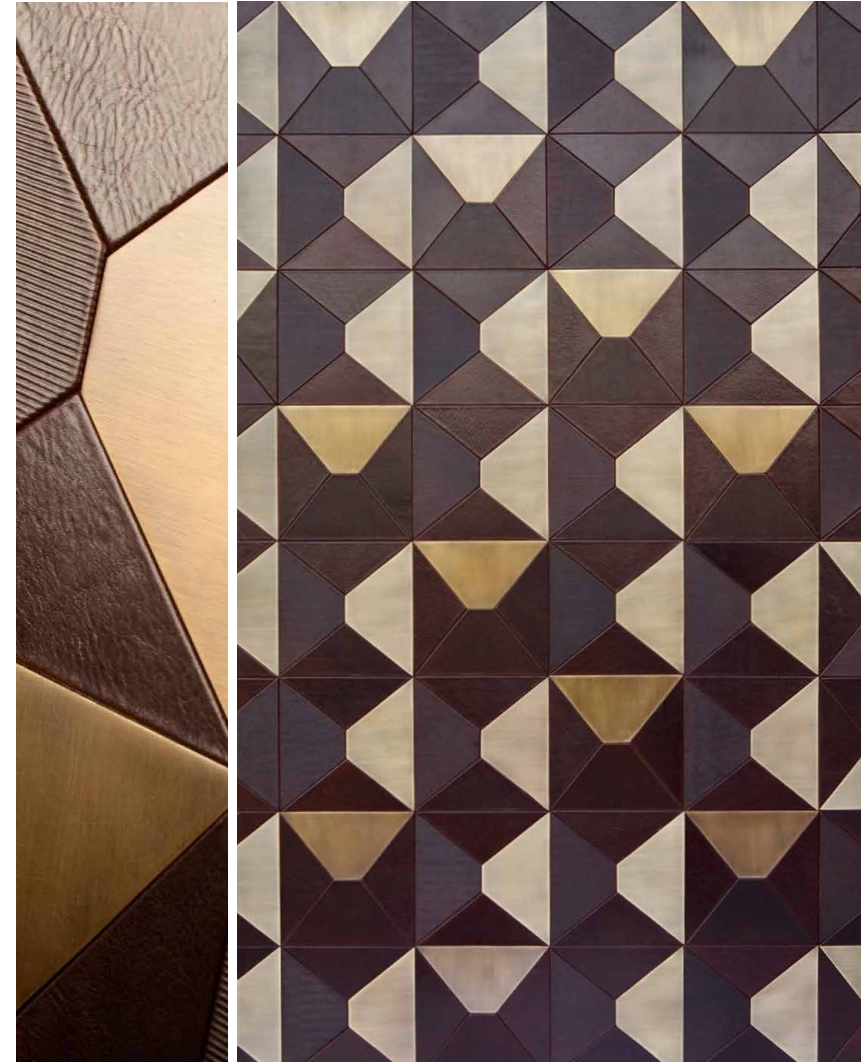

chicago

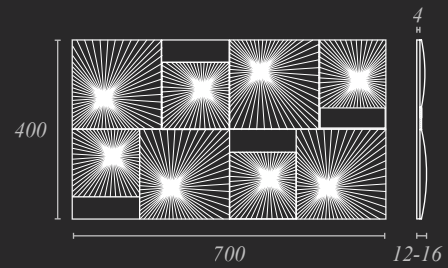

PATTERN REPEAT

400 x 700 mm
27.5 x 16 inch

TECHNIQUE

Embossing: Motif- EM Flange

MATERIAL

Leather - Old Fashion, Ruggine PC

COMPONENT

Tiles- Rectangle Flat,
Square Padded

Refer to our material catalogues for material/finish options

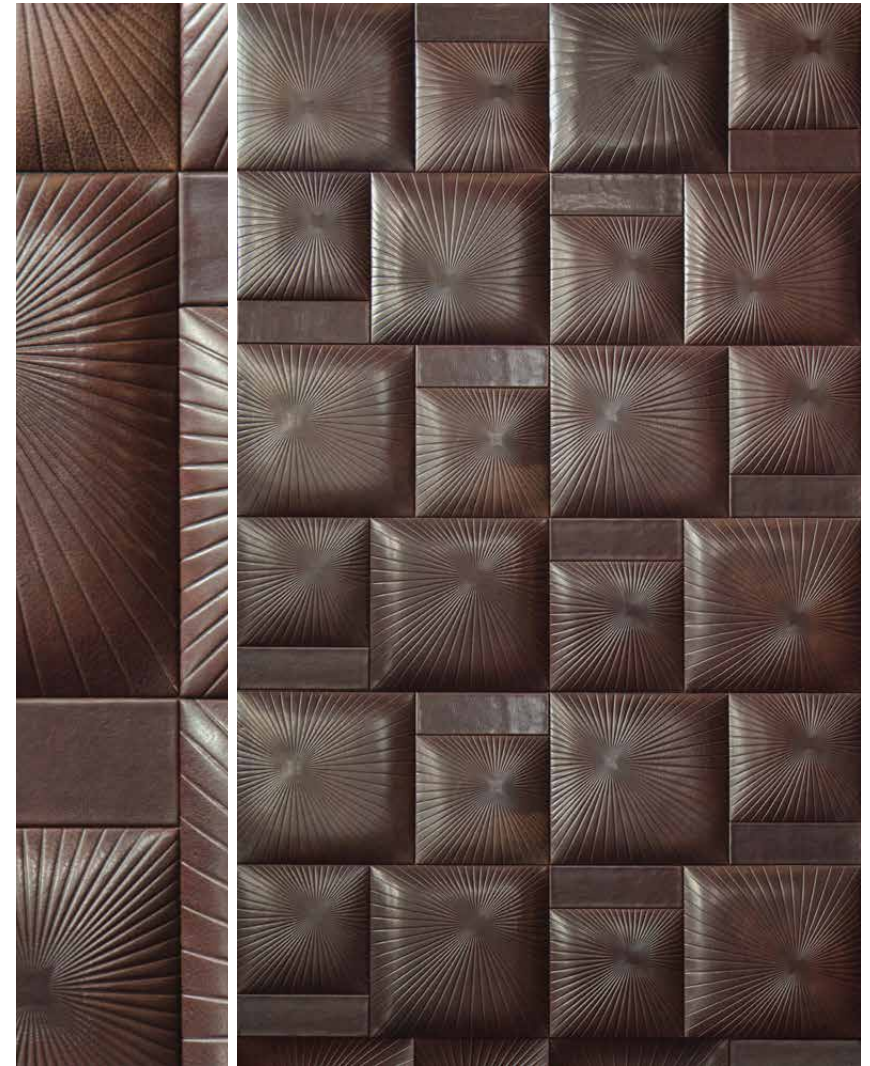



cuboid

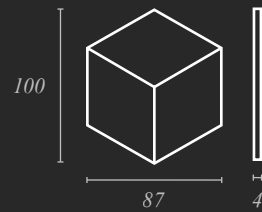

PATTERN REPEAT

100 x 87 mm
3.5 x 4 inch

MATERIAL

Leather - Herringbone, Espresso Black Pearl
*Veneer - Chestnut, Matte**
Metal - Medium Brushed Antique Finish, on Brass

COMPONENT

Tile - Rhombus Flat

Refer to our material catalogues for material/finish options

**Commissioned veneer*

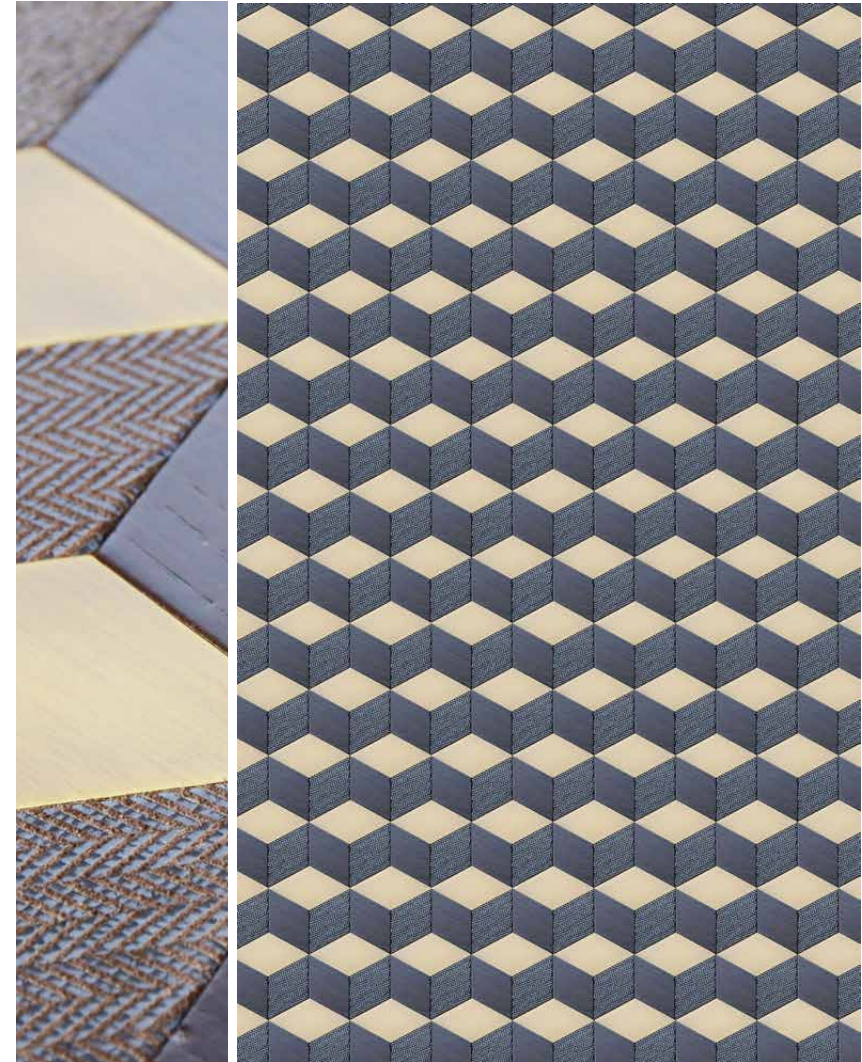



cuboid insert

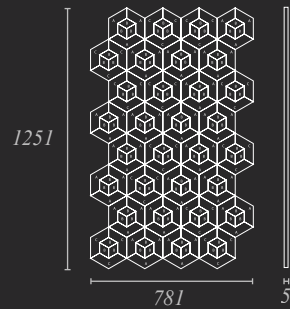

PATTERN REPEAT

1251 x 781 mm

31 x 50 inch

TECHNIQUE

Embossing: Motif - EM Flange

MATERIAL

Leathers - Selene, Gilt*

Olympia, Toffee*

Veneer - Fino Volcano, Grey**

COMPONENT

Tiles - Arrow Flat,

Rhombus Flat

Refer to our material catalogues for material/finish options

* Commissioned leather

** Commissioned veneer



dominion

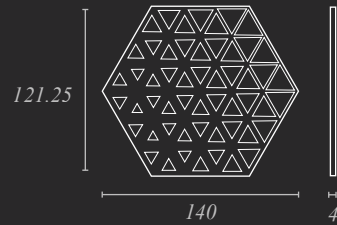

PATTERN REPEAT

140 x 121.25 mm

5.5 x 4.75 inch

TECHNIQUE

Tech Cut: Motif - TC Pyra

MATERIAL

Leather - Classic Soft, Brown

Fabric - Ultra Suede, Brown

COMPONENT

Tile - Hexagon Flat

Refer to our material catalogues for material/finish options

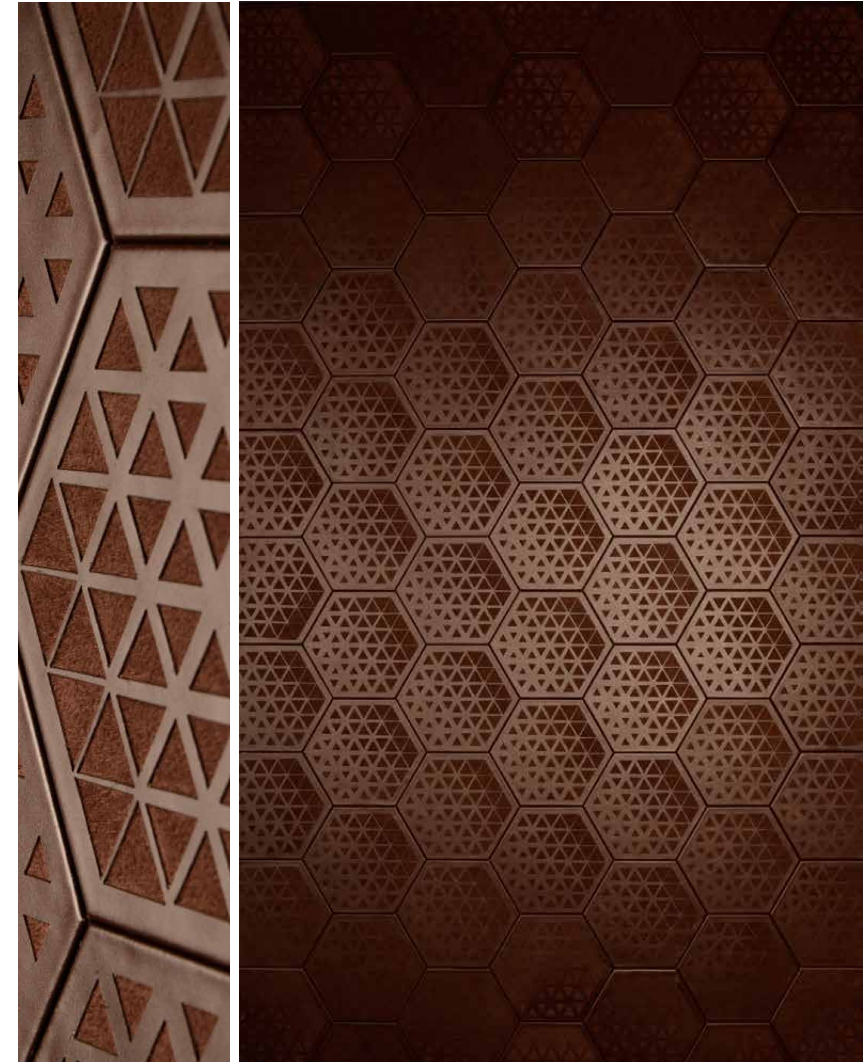

fishscale

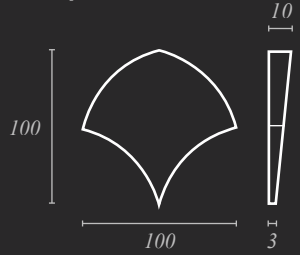

PATTERN REPEAT
100 x 100 mm
4 x 4 inch

MATERIAL
Leather - Old Fashion, Oceano

COMPONENT
Block - Spade Taper

Refer to our material catalogues for material/finish options

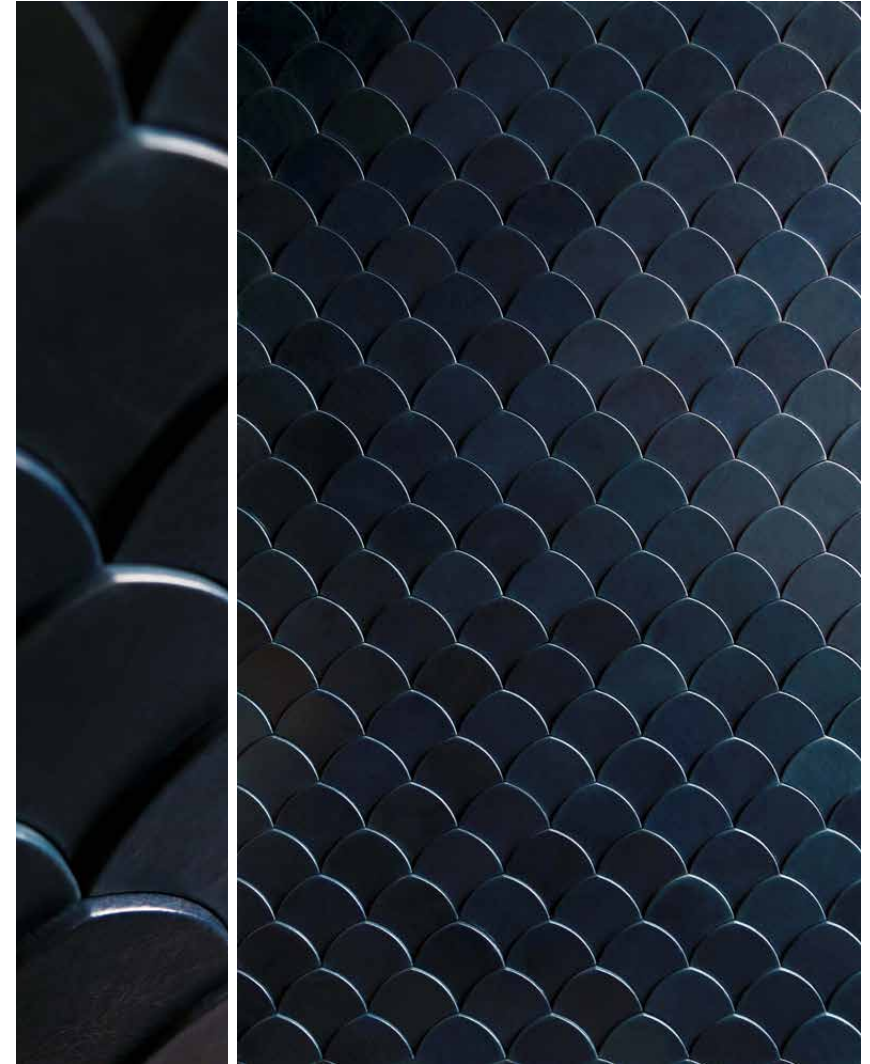



fluted

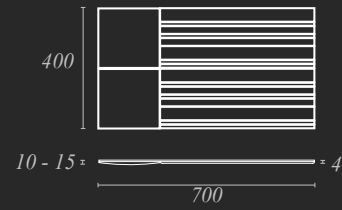

PATTERN REPEAT

400 x 700 mm

27.5 x 16 inch

MATERIAL

Leather - Classic Soft, New Grey

COMPONENT

Tiles - Square Padded,
Rectangle Padded

Refer to our material catalogues for material/finish options



harlem

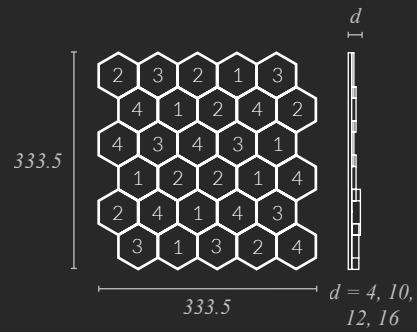

PATTERN REPEAT

333.5 x 333.5 mm
13 x 13 inch

MATERIAL

Leathers - Halo, Black Pearl
Croco Imprint, Black
Marine Rich, Black
Identity, Black Anthracite

COMPONENT

Tile - Hexagon Flat,
Block - Hexa Block

Refer to our material catalogues for material/finish options



ion

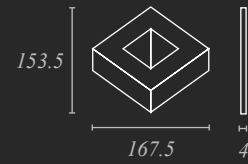

PATTERN REPEAT
153.5 x 167.5 mm
6 x 6.5 inch

MATERIAL

Leathers - Classic Soft, Dark Grey
Classic Soft, Light Grey
Classic Soft, New Grey

COMPONENT

Tile - Triangle Flat

Refer to our material catalogues for material/finish options



lima

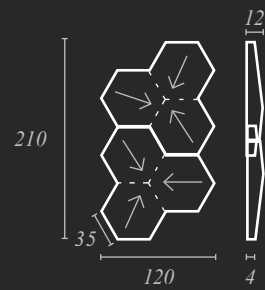

PATTERN REPEAT

210 x 120 mm
4,75 x 8 inch

MATERIAL

Leather - Scala, Taupe

COMPONENT

Block - Hexa Trio

Refer to our material catalogues for material/finish options

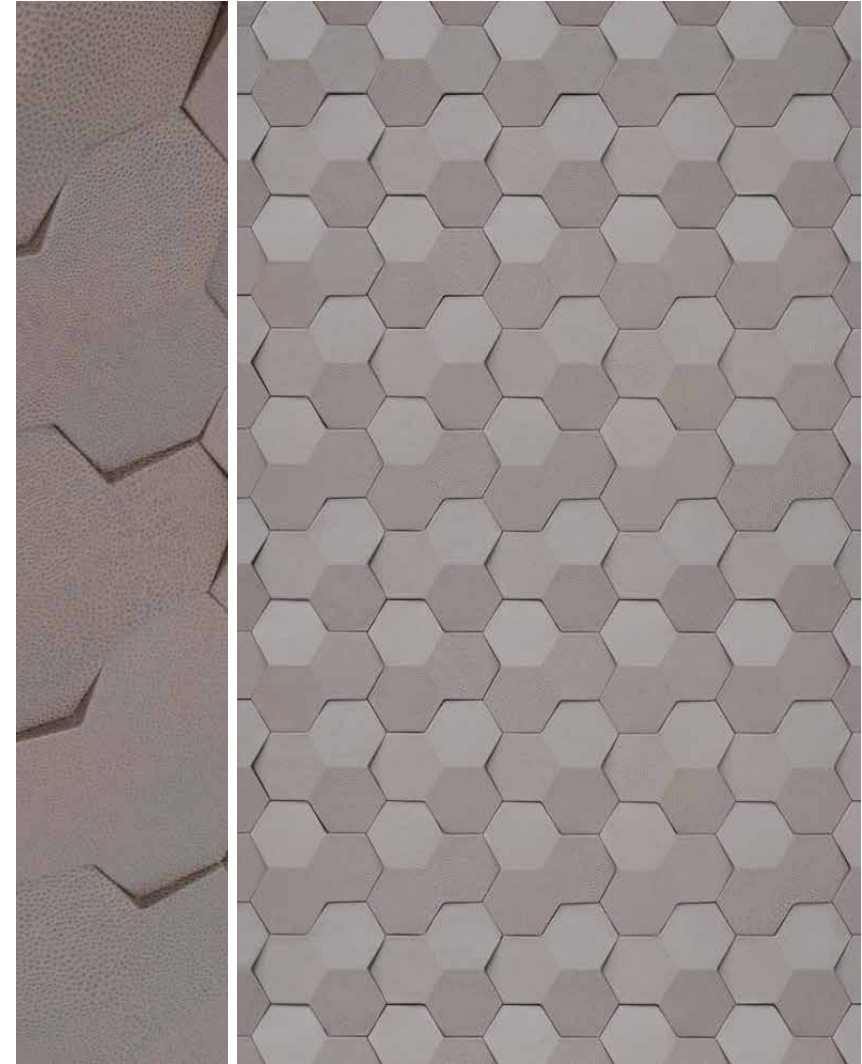

lima

application

WALL FEATURE



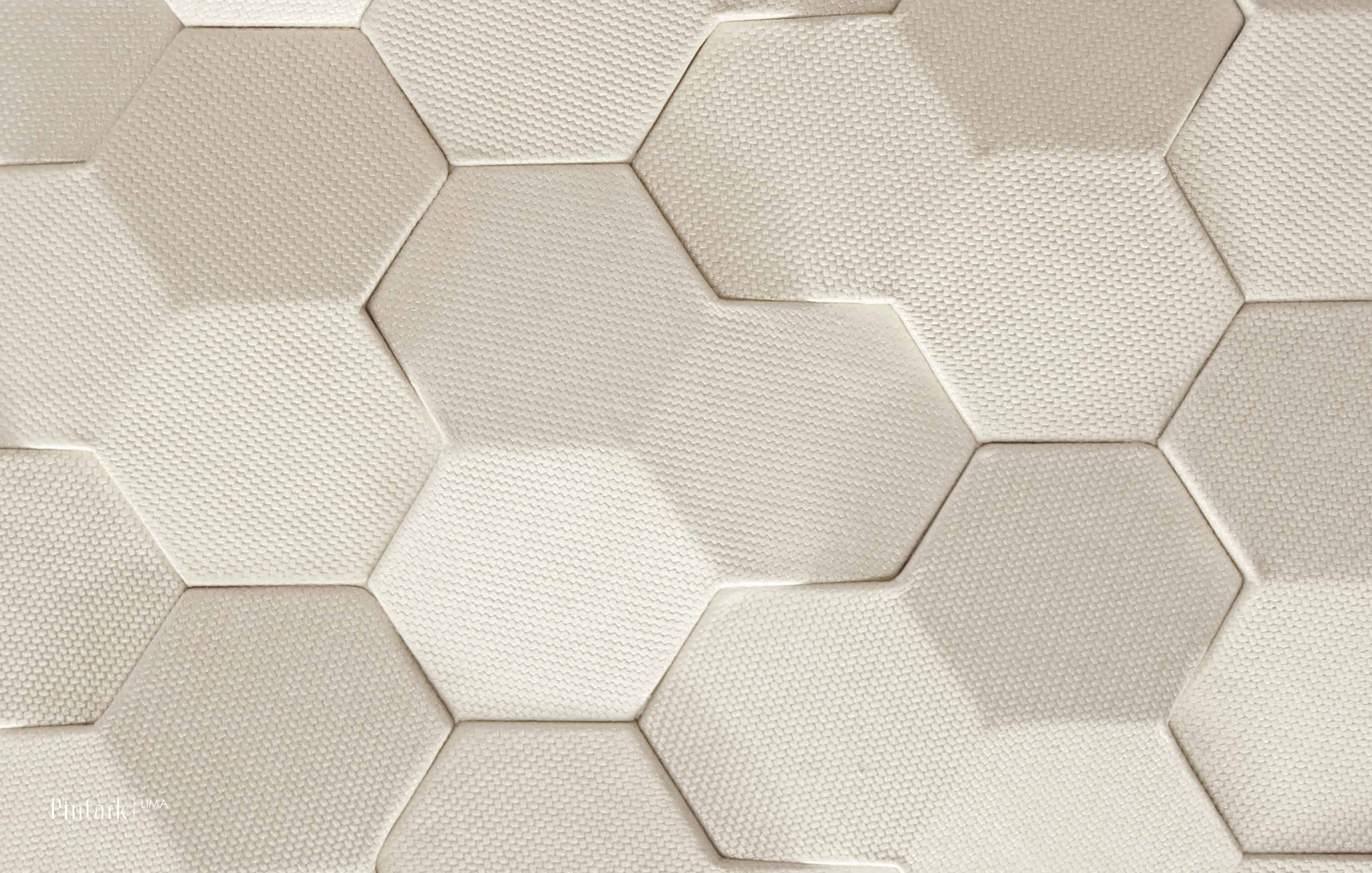

montgomery



PATTERN REPEAT

400 x 100 mm
4 x 16 inch

MATERIAL

Leather - Classic Soft, Brown

COMPONENT

Tiles - Rectangle Flat,
Rectangle Padded

Refer to our material catalogues for material/finish options



montgomery
application

WALL FEATURE

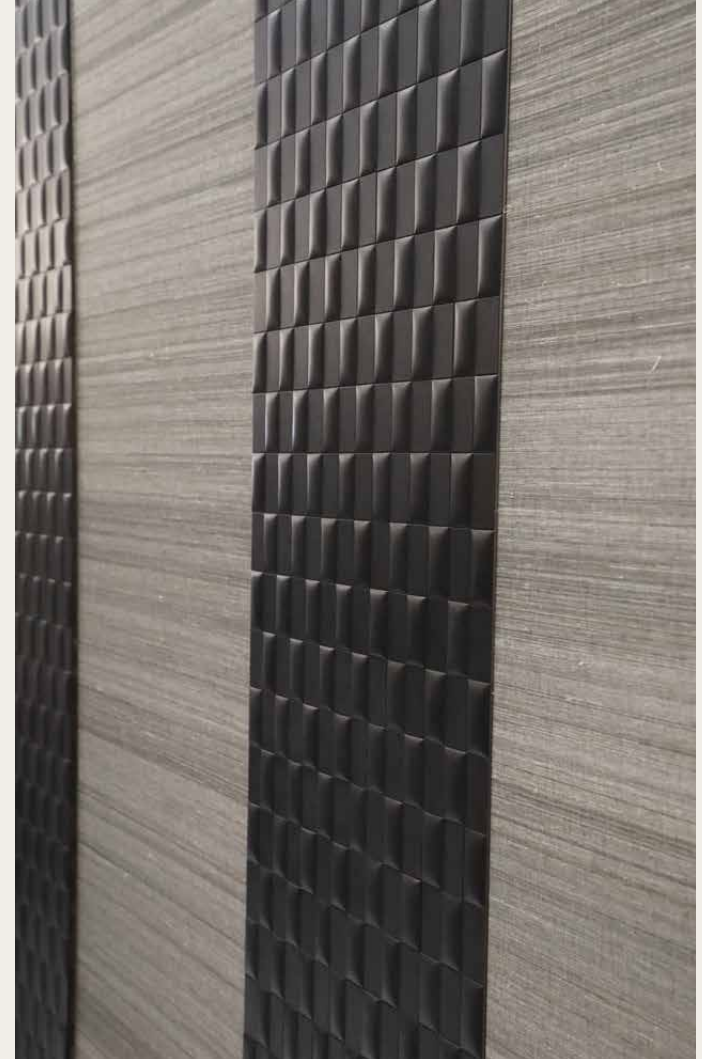

new mexico

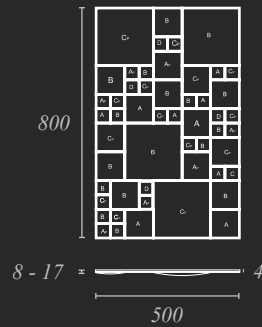

PATTERN REPEAT

800 x 500 mm

19.5 x 31.5 inch

MATERIAL

Leathers - Herringbone, Cream Pearl
Classic Soft, Beige
Brush Stroke, Cream Pearl*
Metal - Brushed Nickel Finish, on Brass*

COMPONENT

*Tiles - Square Flat,
Square Padded*

Refer to our material catalogues for material/finish options

** Commissioned leather*



pisco

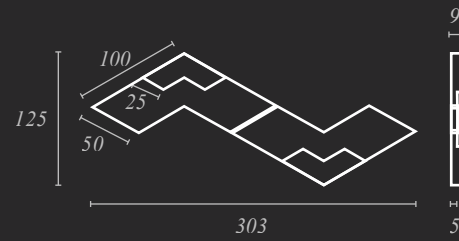

PATTERN REPEAT

125 x 303 mm
12 x 5 inch

MATERIAL

Leather - Crunch, Ox Blood

COMPONENT

Block - Arrow Double Tip

Refer to our material catalogues for material/finish options



porto

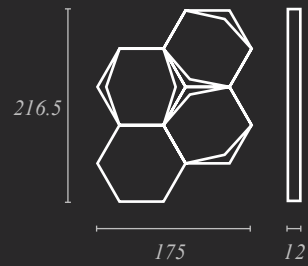

PATTERN REPEAT

216.5 x 175 mm

7 x 8.5 inch

MATERIAL

Leathers - Classic Soft, Light Grey
Mini Teju Lizard, Stormy

COMPONENT

Blocks - Hexa Block, Hexa Oblique

Refer to our material catalogues for material/finish options

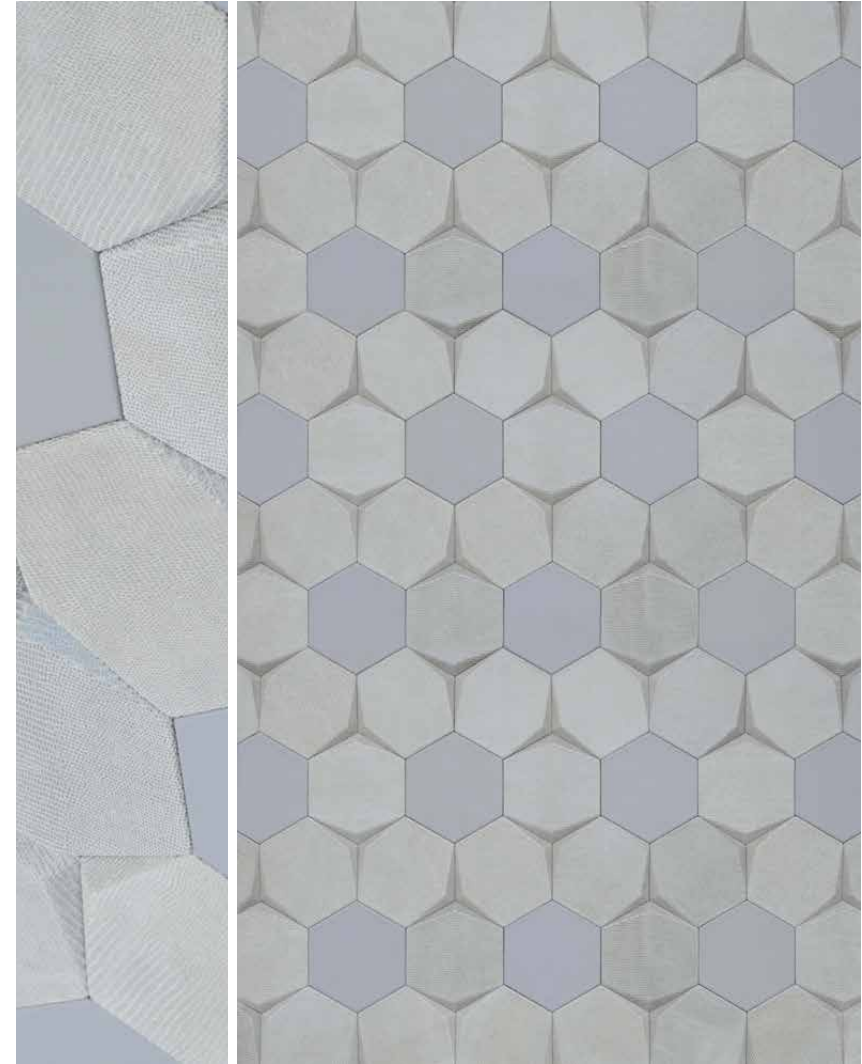



shanghai

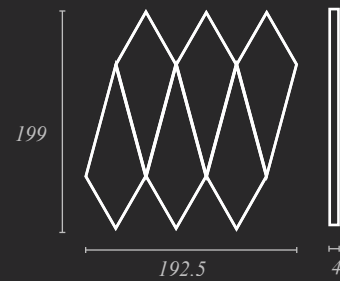

PATTERN REPEAT

199 x 192.5 mm
7.5 x 7.8 inch

MATERIAL

Leather - Classic Soft, Nude
Veneer - Fino Volcano, Matte*
Metal - Medium Brushed Antique Finish, on Brass

COMPONENT

Tile - Kite Flat

Refer to our material catalogues for material/finish options

* Commissioned veneer

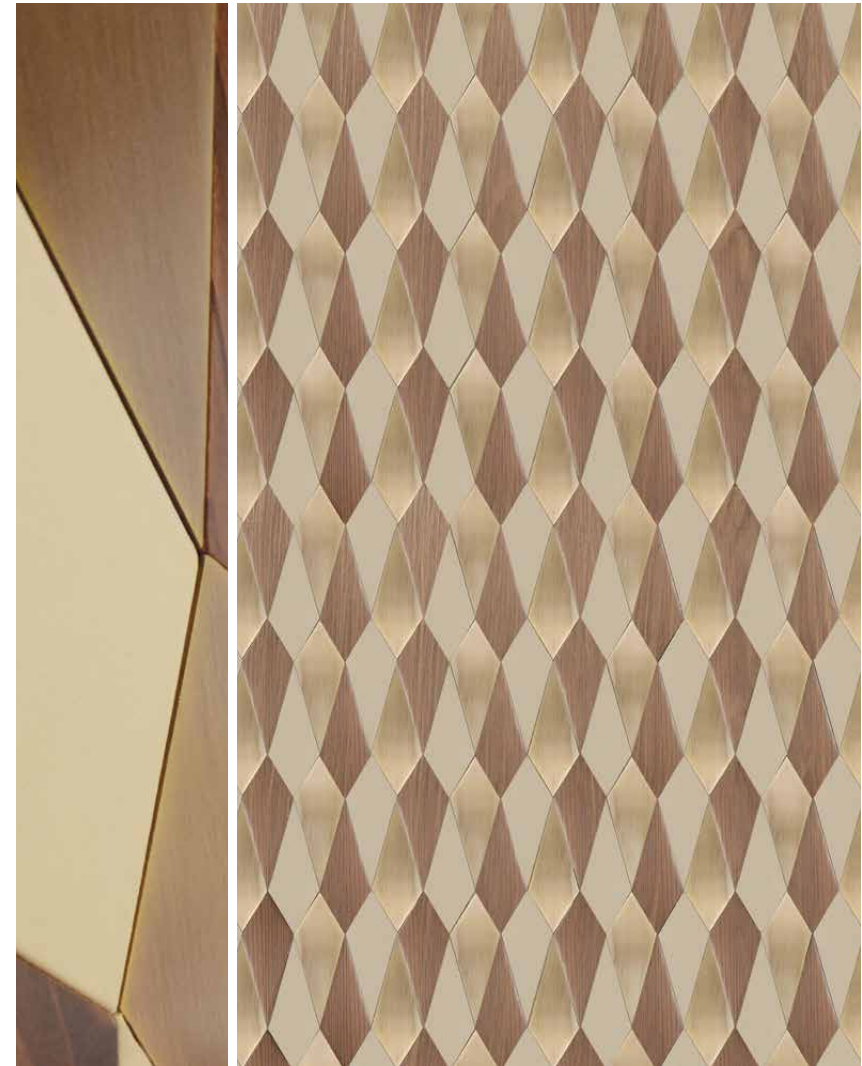

taza

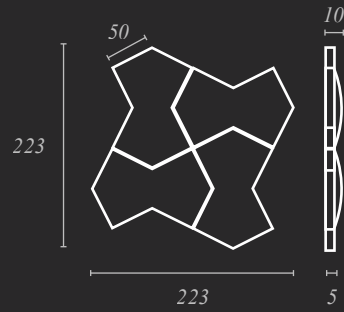

PATTERN REPEAT

223 x 223 mm
8.75 x 8.75 inch

MATERIAL

Leathers - Classic Soft, Brown
Herringbone, Espresso Black Pearl

COMPONENT

Tiles - Bow Flat, Bow Padded

Refer to our material catalogues for material/finish options

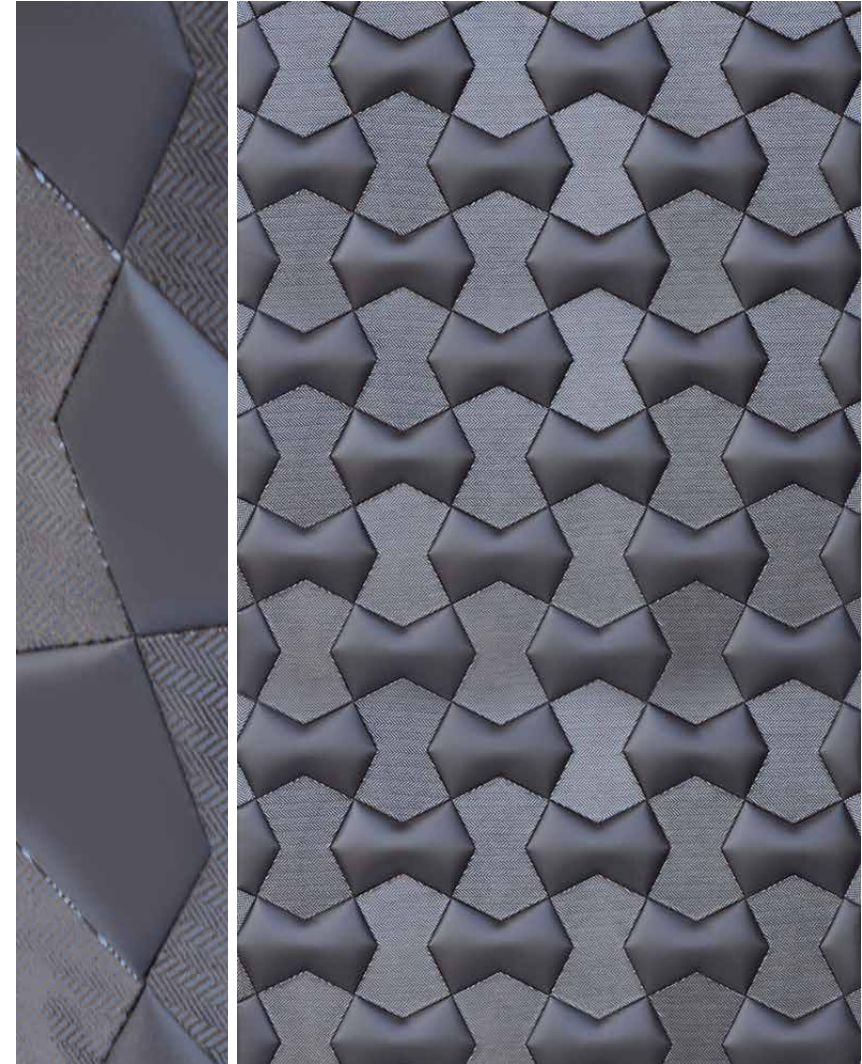



taiz

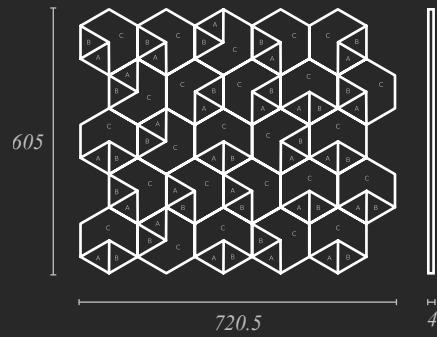

PATTERN REPEAT

605 x 720.5 mm
23.75 x 28.25 inch

MATERIAL

Leather - Crunch, Camel*
Veneer - Ivory Oak, Matte
Metal - Medium Brushed Antique Finish, on Brass

COMPONENT

Tiles - Arrow Flat,
Triangle Flat

Refer to our material catalogues for material/finish options

* Commissioned leather

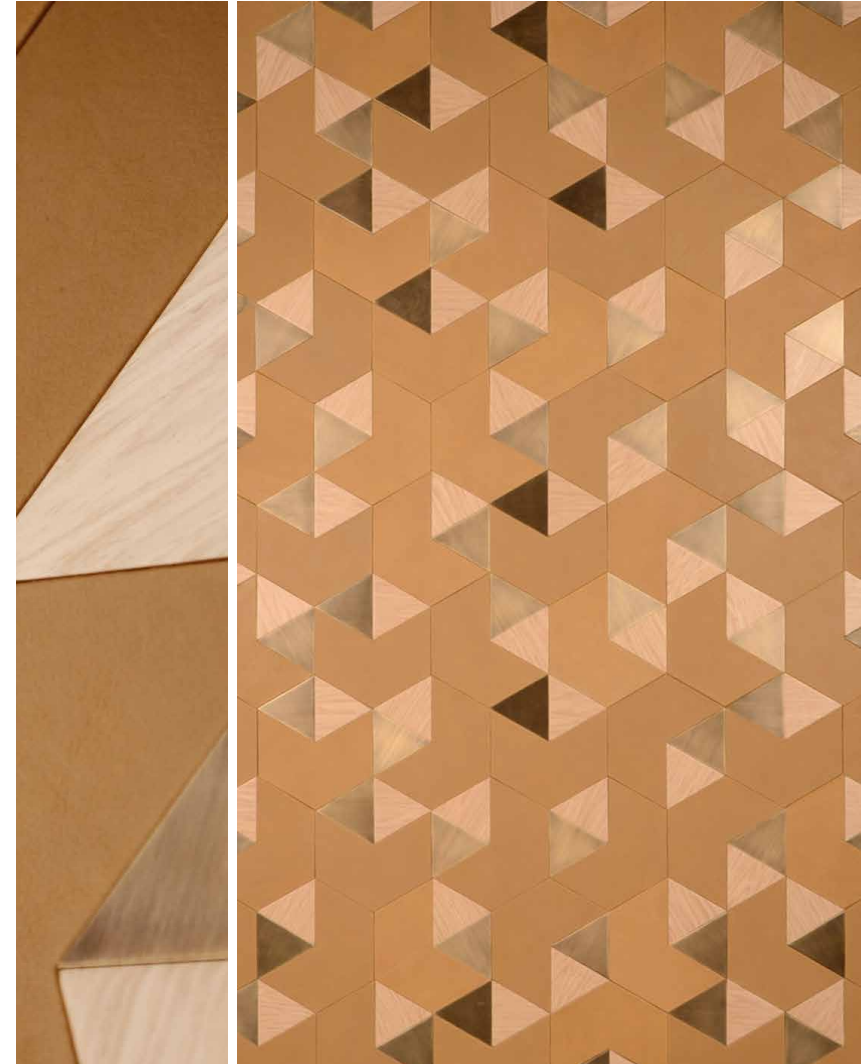

tokyo

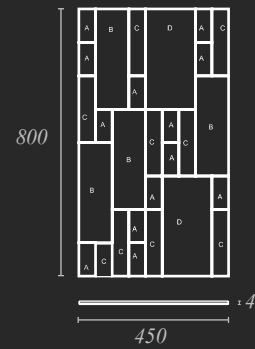

PATTERN REPEAT

800 x 450 mm

18 x 31.5 inch

MATERIAL

Leathers - Matchpoint, Smoke Black Pearl*

Brighton, Pewter*

Chevron, Espresso

COMPONENT

Tile - Rectangle Flat

Refer to our material catalogues for material/finish options

* Commissioned leather



tokyo mini

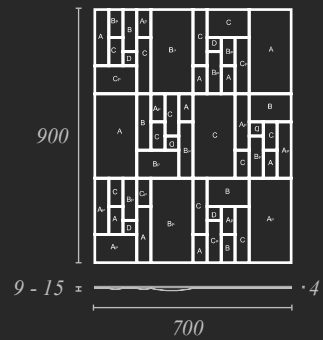

PATTERN REPEAT

900 x 700 mm
27.5 x 35.5 inch

MATERIAL

Leathers - Selene, Eucalyptus*
Mini Teju Lizard, Stormy
Doral, Meadowland*
Metal - High Gloss Nickel Finish, on Brass, Hammered**

COMPONENT

Tiles - Square Flat,
Rectangle Flat,
Rectangle Padded

Refer to our material catalogues for material/finish options

* Commissioned leather

** Commissioned metal finish



truno

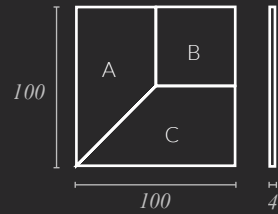

PATTERN REPEAT

100 x 100 mm

4 x 4 inch

TECHNIQUE

Embossing: Motif - EM Mesquite

MATERIAL

Leathers - Domain, Cool Grey*

Marine Rich, Black

Metal - Medium Brushed Antique Finish, on Brass

COMPONENT

Tiles - Square Flat,
Rectangle Cut Flat

Refer to our material catalogues for material/finish options

*Commissioned leather

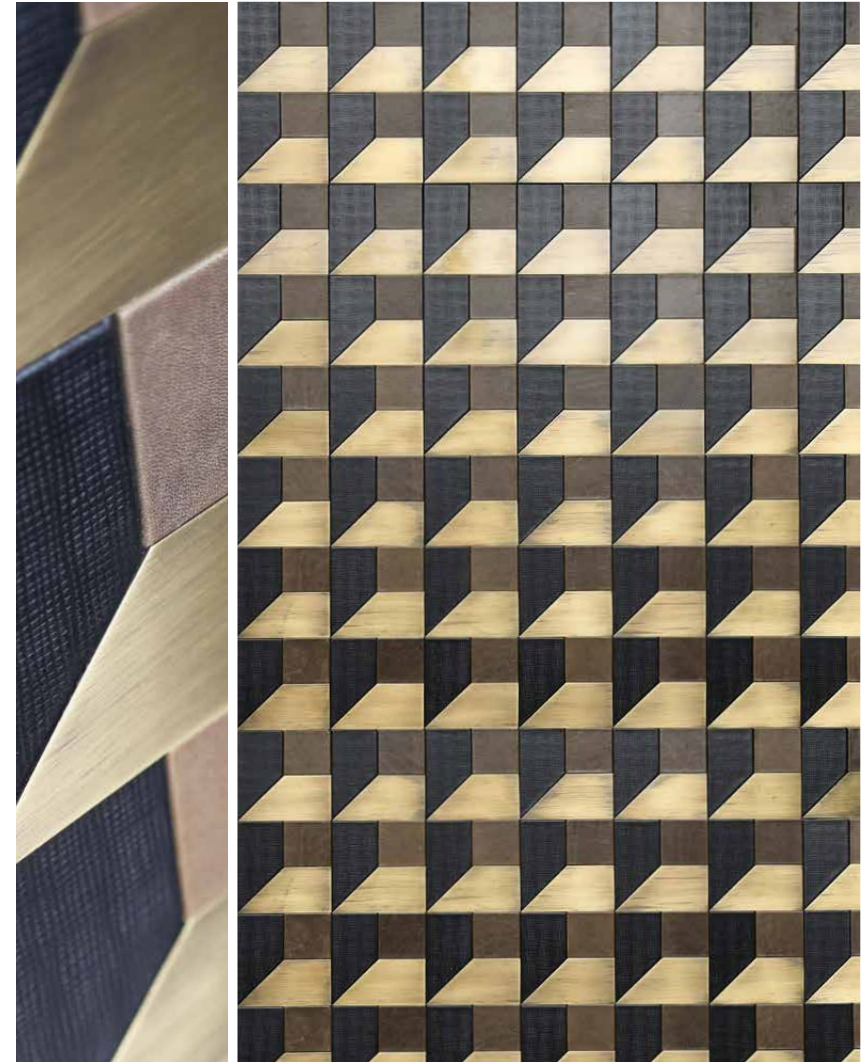

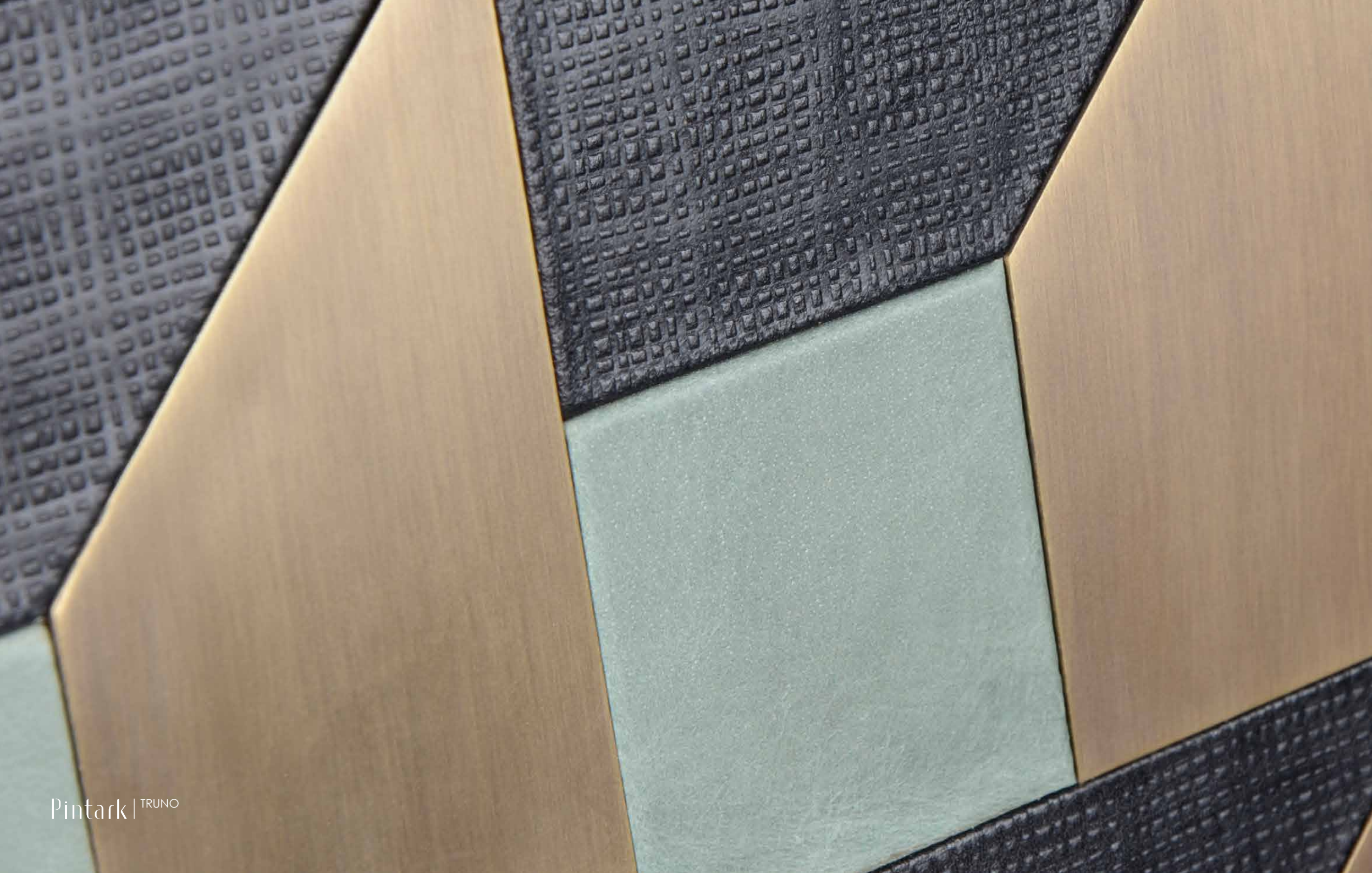

westminster

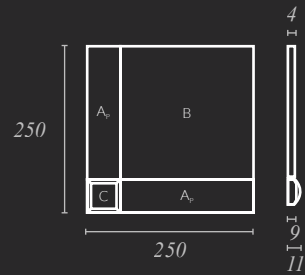

PATTERN REPEAT

250 x 250 mm
10 x 10 inch

MATERIAL

Leathers - *Classic Soft, New Grey
Identity, Cream New Pewter**
Metal - *Brushed Nickel Finish, on Brass*

COMPONENT

Tiles - *Square Flat,
Rectangle Padded*

Refer to our material catalogues for material/finish options

*Commissioned leather



isa.

*patterns creating
continuous surfaces*

Aimed at offering customers continuous surface solutions, Isa surfaces are in-house designs that are developed and fully assembled to bespoke sizing.

Isa surfaces enjoy the use of techniques such as weaving to create softer, layered, surfaces that are best suited for large coverages.

Ideal for interior features such as feature walls, large format shutters and doors, partitions and free standing screens.

battersea

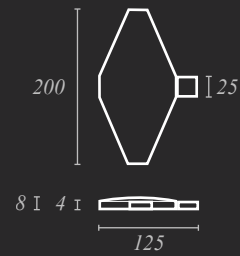

PATTERN REPEAT

157 x 55 mm

7.85 x 5 inch

MATERIAL

Leathers - *Chevron, Blue Space Moon*
Classic Soft, Navy Blue
Metal - *Brushed Nickel Finish, on Brass*

COMPONENT

Tiles - *Rhombus Flat Tip,*
Rhombus Flat Tip Padded

Refer to our material catalogues for material/finish options

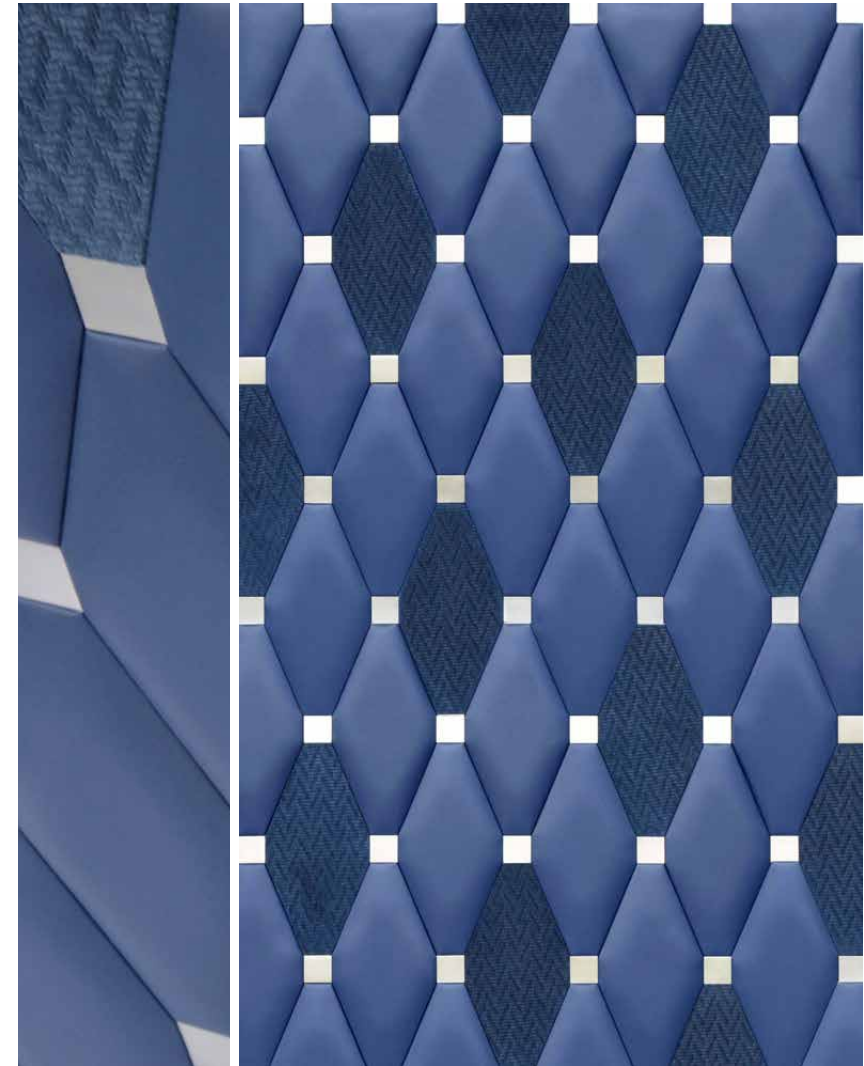

dara

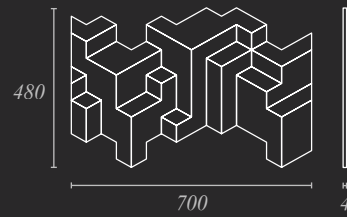

PATTERN REPEAT

700 x 480 mm

27.5 x 18.75 inch

MATERIAL

Leathers - Brighton, Pewter*

Linia, 612

Linia, 667*

COMPONENT

NA

Refer to our material catalogues for material/finish options

* Commissioned leather



edin

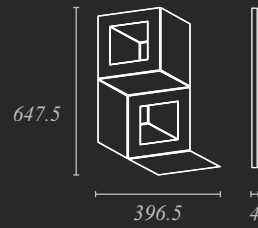

PATTERN REPEAT

396.5 x 647.5 mm
15.5 x 25.5 inch

MATERIAL

Leathers - Classic Soft, Olive
Classic Soft, New Grey
Classic Soft, Nude

COMPONENT

NA

Refer to our material catalogues for material/finish options

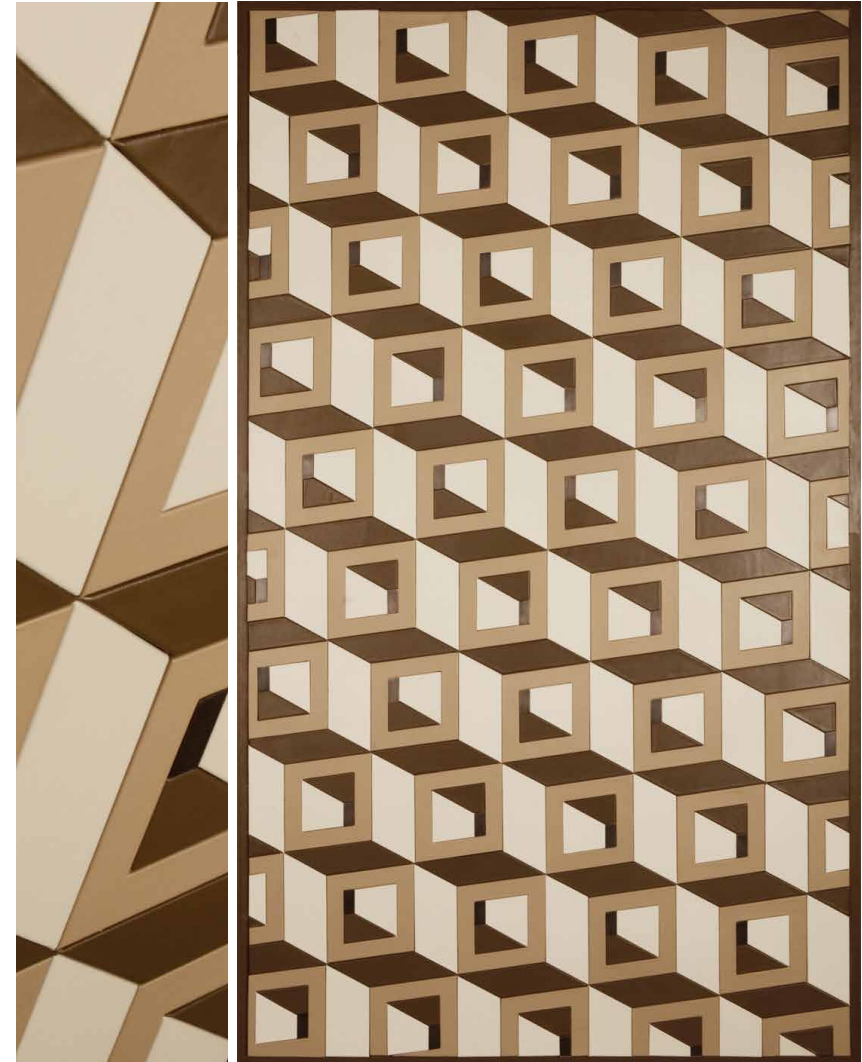

fez

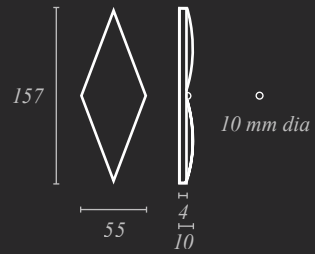

PATTERN REPEAT

157 x 55 mm
6 x 2 inch

MATERIAL

Leather - Classic Soft, Nude
Acrylic - Blue
Metal - High Gloss Finish, on Brass*

COMPONENT

Tile - Rhombus Padded

FEATURE

Backlit

Refer to our material catalogues for material/finish options

* Light mechanism to be supplied and fitted by specifier/fitter.

** Commissioned metal finish

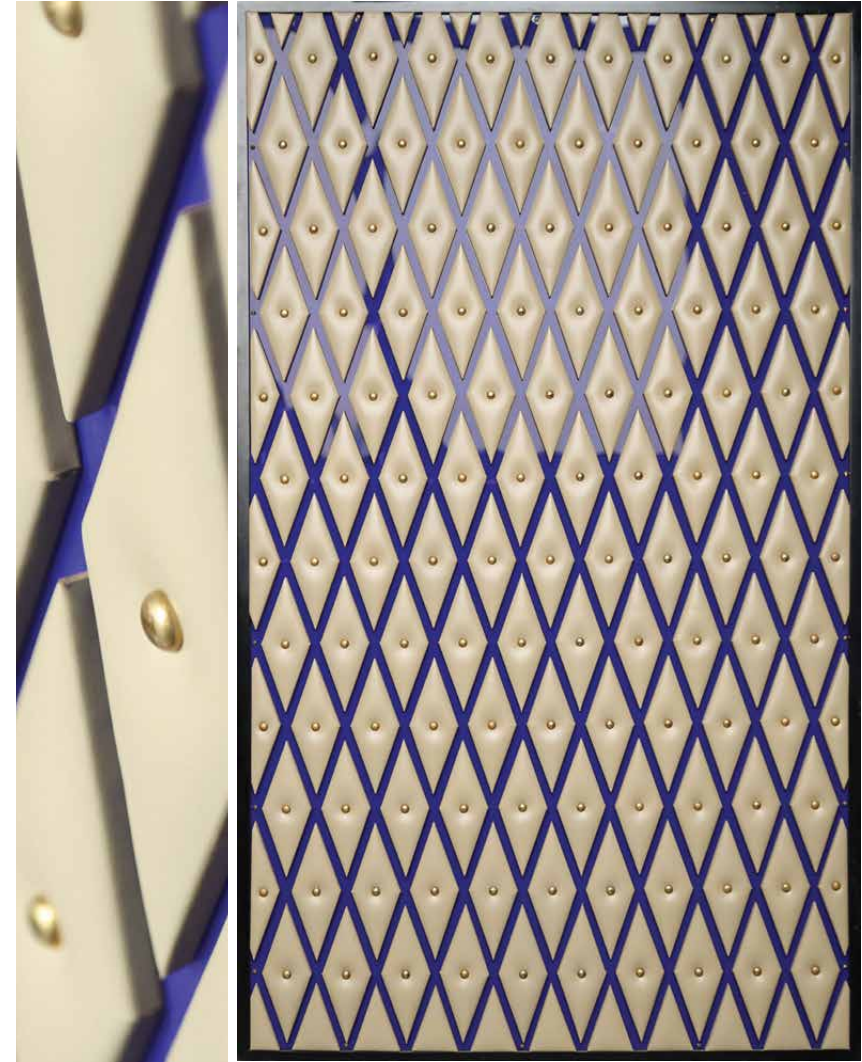

fiore

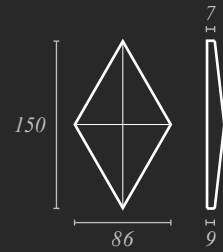

PATTERN REPEAT

86 x 150 mm

3.25 x 6 inch

MATERIAL

Leather - Crunch, Cocoa*

Acrylic - White

COMPONENT

Block - Rhombus Cross Taper

FEATURE

Backlit

Refer to our material catalogues for material/finish options

* Light mechanism to be supplied and fitted by specifier/fitter.

** Commissioned leather

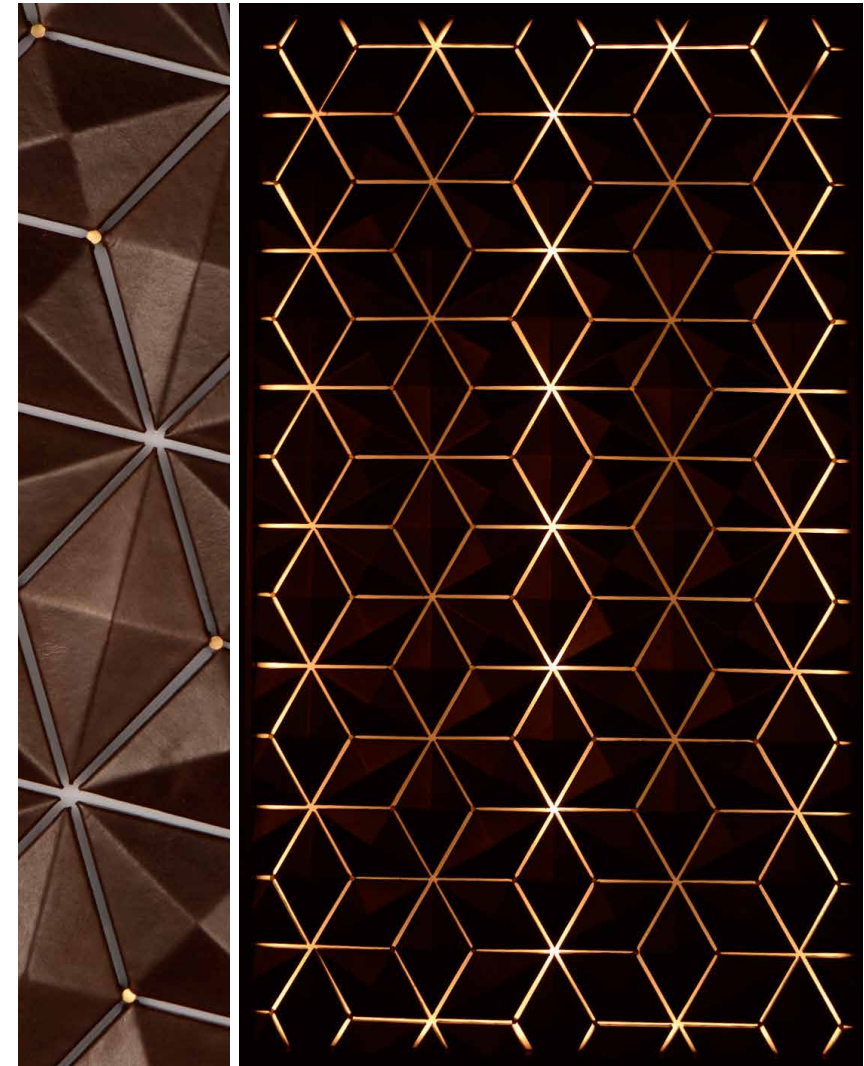

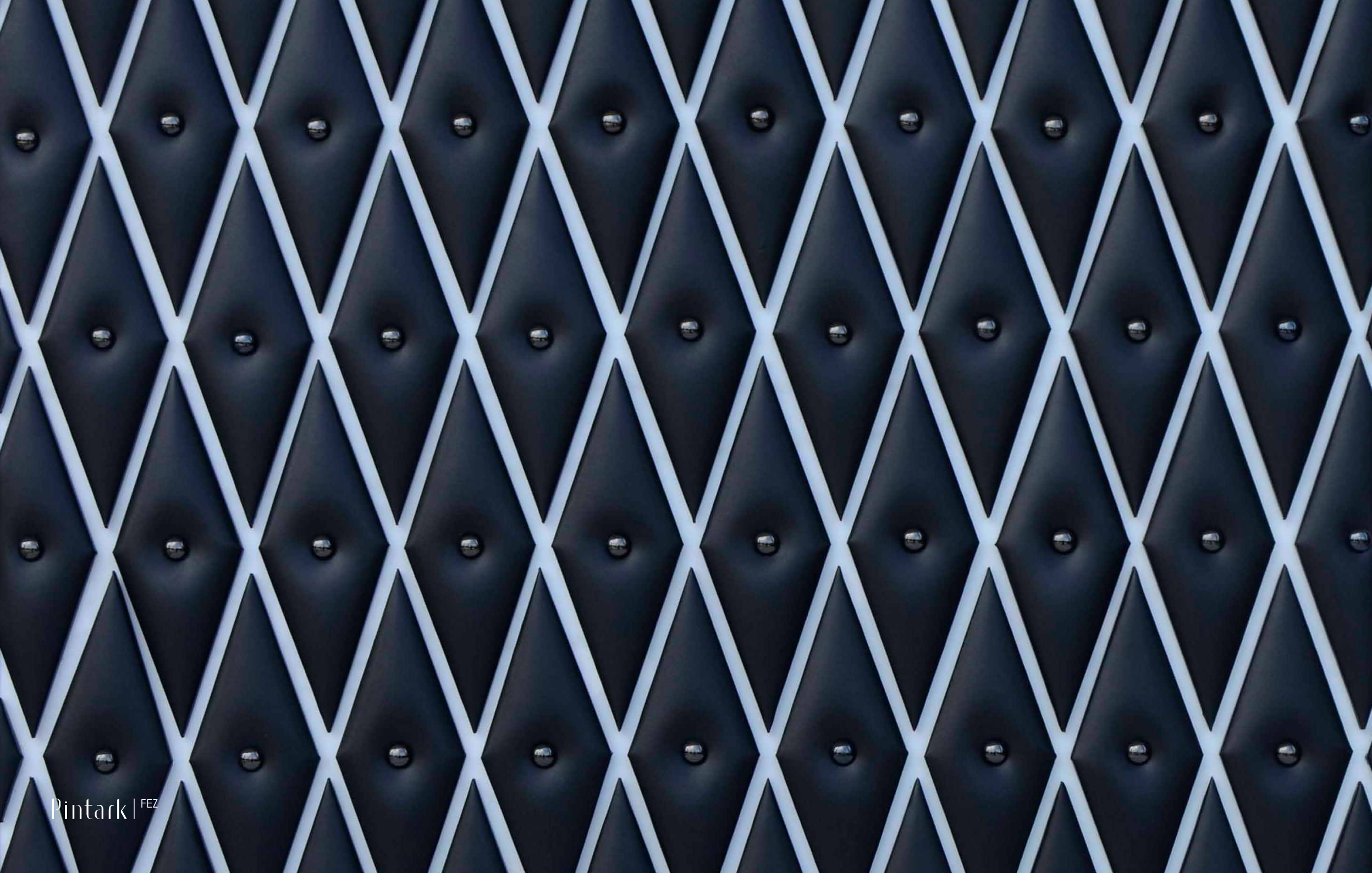

lattice

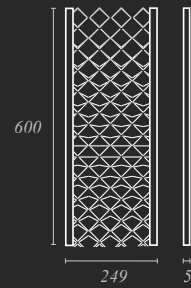

PATTERN REPEAT

600 x 249 mm
23.5 x 9.75 inch

TECHNIQUE

Tech Cut

MATERIAL

Leather - Classic Soft, Black
Fabric - Ultra Suede, Black
Metal - Medium Brushed Antique Finish, on Brass

COMPONENT

NA

Refer to our material catalogues for material/finish options

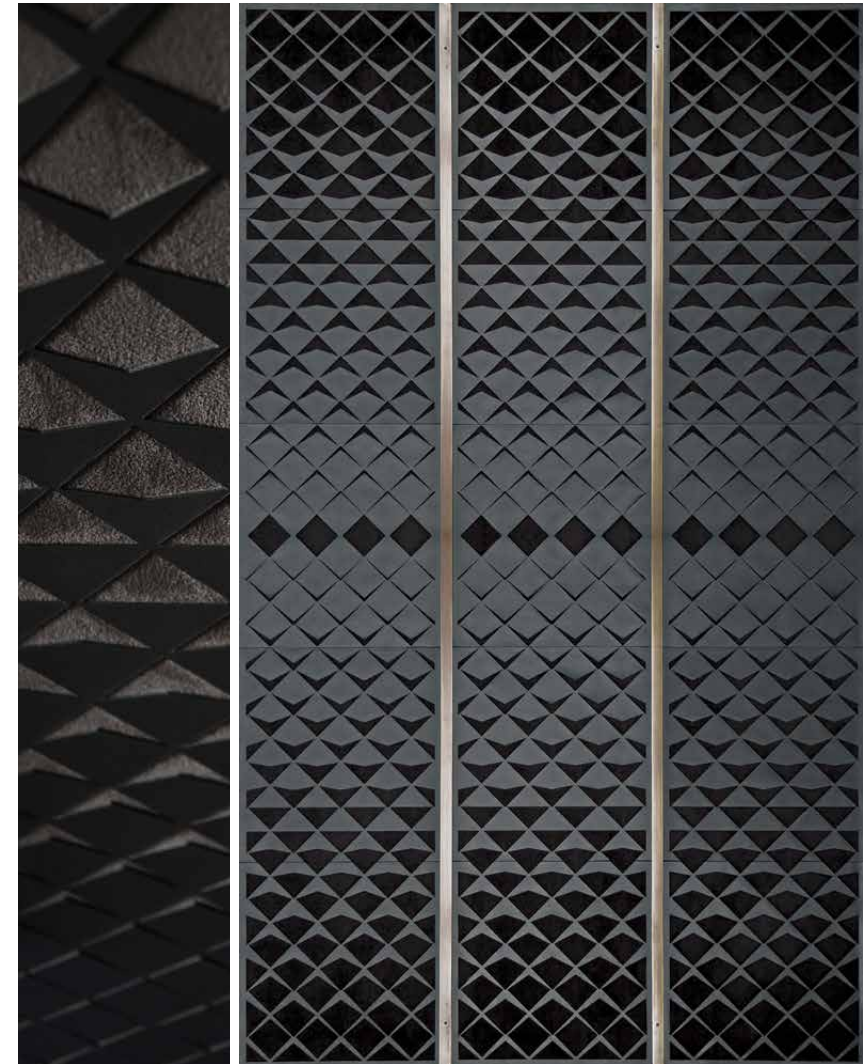

lattice
application

WALL FEATURE



lisson

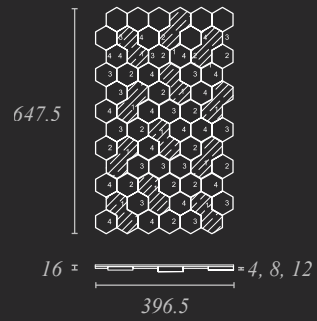

PATTERN REPEAT

647.5 x 396.5 mm
25.5 x 15.5 inch

MATERIAL

Leather - Classic Soft, Olive
Acrylic - White

COMPONENT

Block - Hexa Block

FEATURE

Backlit

Refer to our material catalogues for material/finish options
* Light mechanism to be supplied and fitted by specifier/fitter.

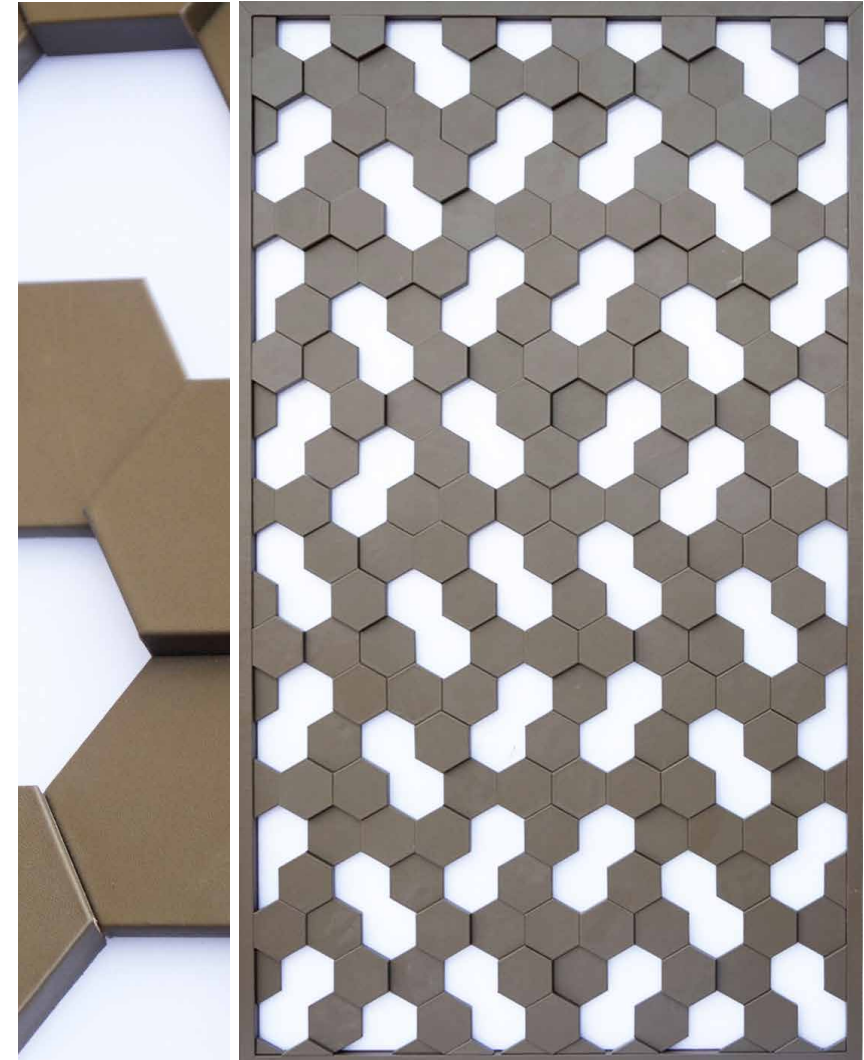

montane

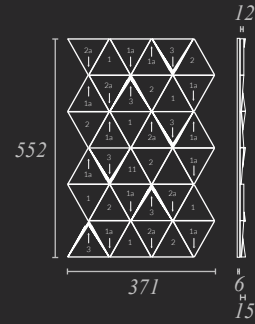

PATTERN REPEAT

371 x 552 mm
14.5 x 21.75 inch

MATERIAL

Leathers - Classic Soft, Nude
Shagreen, Pearl Metallic
Metal - Brushed Orro Finish, on Brass
Acrylic - White

COMPONENT

Block - Triangle, Triangle Taper

FEATURE

Backlit

Refer to our material catalogues for material/finish options
* Light mechanism to be supplied and fitted by specifier/fitter.



turin

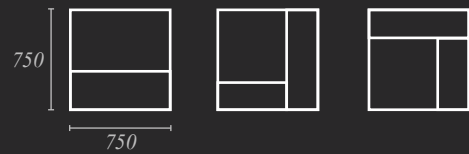

6 x 10 10 x 10 10 x 10

PATTERN REPEAT

750 x 750 mm

29.5 x 29.5 inch

MATERIAL

Leather - Classic Soft, Olive

Metal - Medium Brushed Antique Finish, on Brass

COMPONENT

NA

Refer to our material catalogues for material/finish options



verona

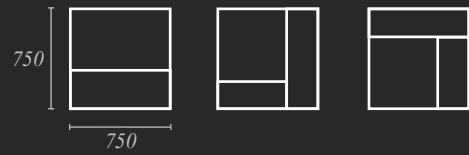

PATTERN REPEAT

750 x 750 mm

29.5 x 29.5 inch

MATERIAL

Leather - Classic Soft, Pewter

Metal - High Gloss Stainless Steel*

COMPONENT

NA

Refer to our material catalogues for material/finish options

* Commissioned metal



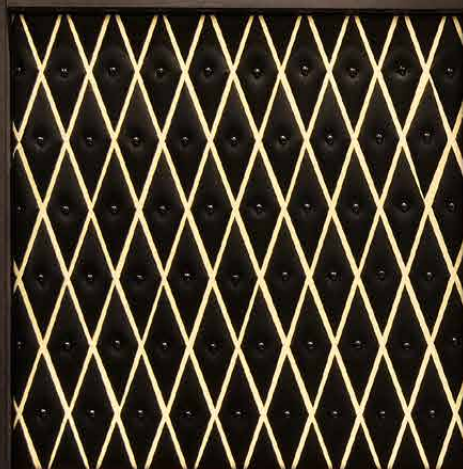

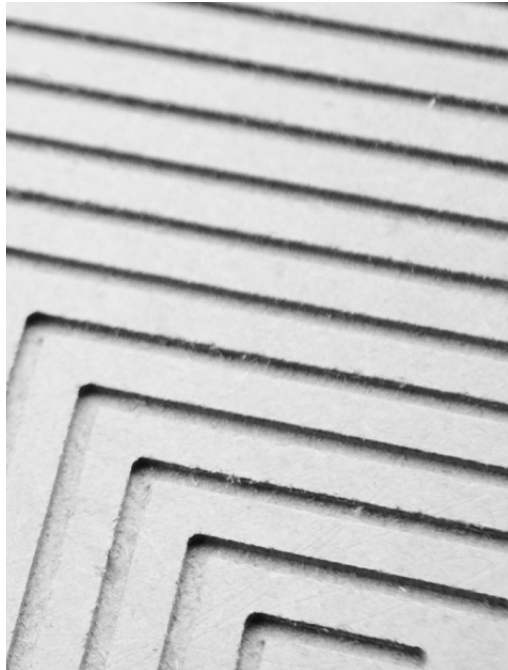

Pintark

SYSTEMS.

Striving to create forward thinking systems of application and to offer the most innovative solutions, Pintark develops adaptable surface systems that aim to provide flexibility in application.

manhattan.

An advanced surface treatment, adapted as value addition on existing surfaces or employed to create new surfaces - highlighting unique materials with crisp minimal detailing.

Ranging from traditional materials such as leathers and veneers to new age materials such as carbon fibres and stain-resistant fabrics, the system offers infinite possibilities for walls, doors, partitions and furniture features.

Simple dowel installation liberates from size constraints and base finish limitations.

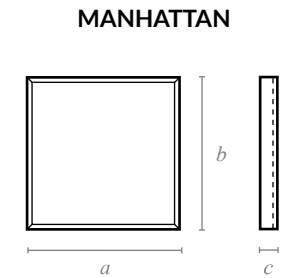
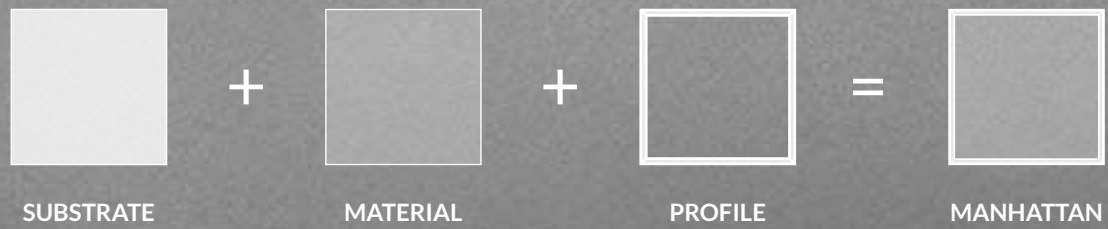

SIZING

	<i>Min</i>	<i>Max</i>
Luxe Leather	100 x 100 mm, 4" x 4"	550 x 550 mm, 22" x 22"
Prima Leather	100 x 100 mm, 4" x 4"	550 x 550 mm, 22" x 22"
Essential Leather	100 x 100 mm, 4" x 4"	550 x 550 mm, 22" x 22"
Faux Leather	100 x 100 mm, 4" x 4"	1200 x 2400 mm, 48" x 96"
Tech Fabric	100 x 100 mm, 4" x 4"	1200 x 2400 mm, 48" x 96"
Veneer	100 x 100 mm, 4" x 4"	1200 x 2400 mm, 48" x 96"
Decoupage	100 x 100 mm, 4" x 4"	900 x 2400 mm, 36" x 96"
Carbon Fibre	100 x 100 mm, 4" x 4"	800 x 2400 mm, 32" x 96"
Vintage Brass	100 x 100 mm, 4" x 4"	350 x 1200 mm, 14" x 48"



Systems Advantages

MINIMAL
DETAILING.

INFINITE
POSSIBILITIES.

EASY
INSTALLATION.

VALUE
ADDITION.

manhattan

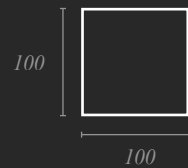

100 x 100 mm

4 x 4 inch

MATERIAL

Leather - *Signature, Papillon, Cobblestone**

Veneer - *Platinum Wenge, Matte***

Metal Profile - *Pewter****

Refer to our material catalogues for material/finish options

* Commissioned leather

** Commissioned veneer

*** Commissioned metal finish



manhattan

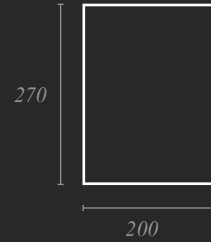

270 x 200 mm
10.75 x 8 inch

MATERIAL

Leather - Classic Soft, Brown
Carbon Fibre - Honeycomb
Metal Trim - Champagne*

Refer to our material catalogues for material/finish options

* Commissioned Metal Finish

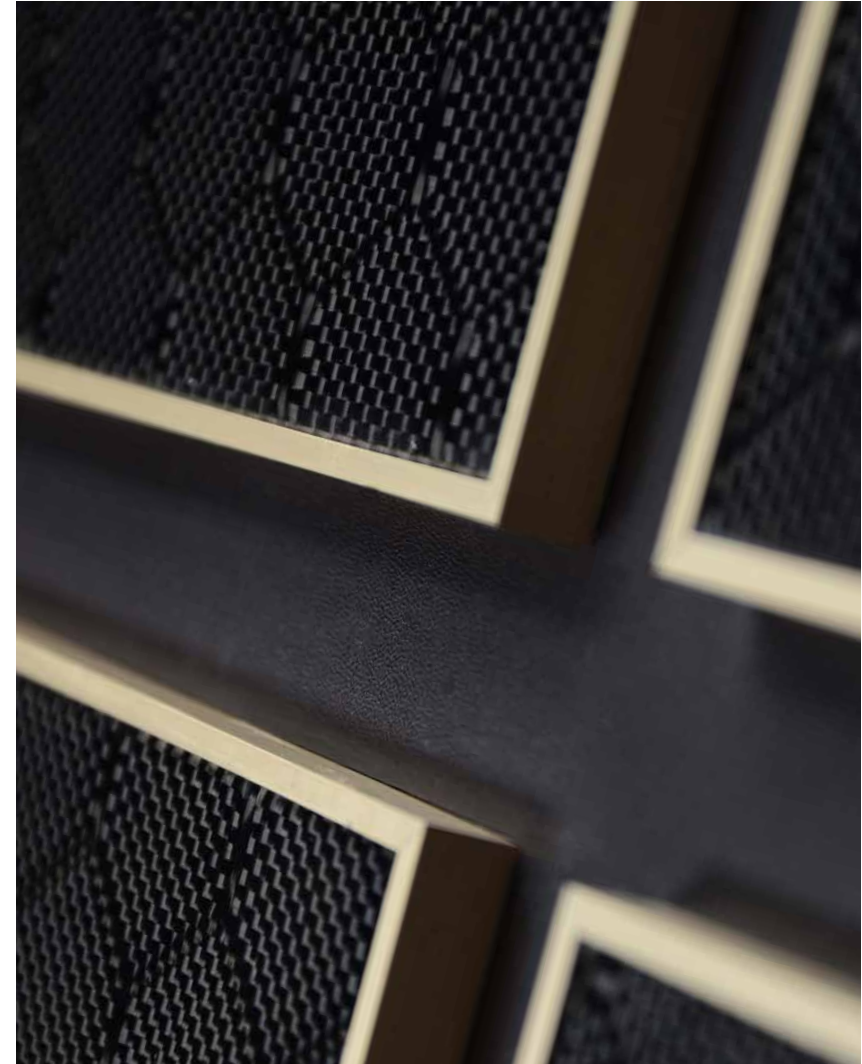

manhattan



270 x 200 mm
10.75 x 8 inch

MATERIAL

Leather - Classic Soft, Brown
Veneer - Swiss Ebony, High Gloss
Metal Trim - Champagne*

Refer to our material catalogues for material/finish options

* Commissioned Metal Finish

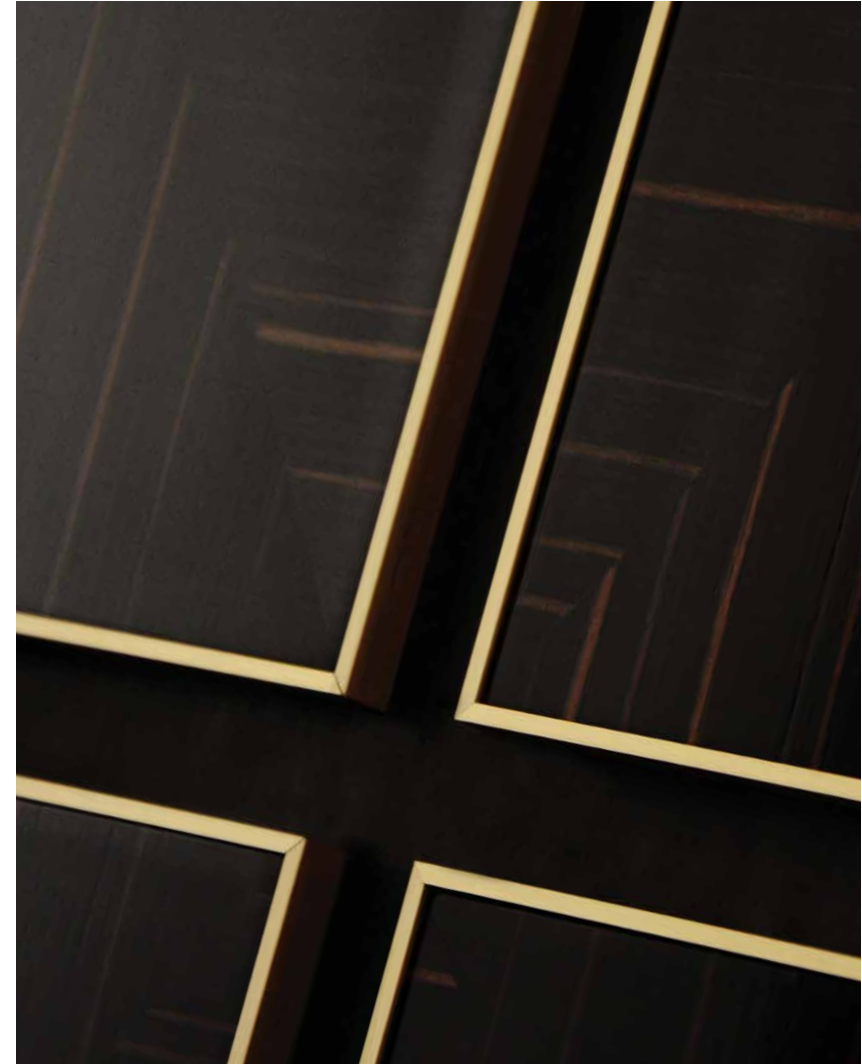

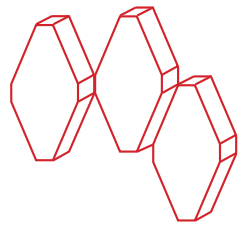

DISCLAIMER.

Component sizes may vary ± 1 mm.

Junctions between metal and adjacent components may experience a gap of up to 0.5 mm.

Metal is a natural material which is directly affected by its environment. Our metal finishes are coated to provide a protective layer, however due to metal's natural properties and depending on the environment, metal finishes may experience patination which in certain circumstances can be seen as desirable.

Leather is a natural material, colour and texture tends to vary from lot to lot and hide to hide.

Depending on component design and size, padding depths range from 7 mm to 28 mm.

Please refer to Pintark Installation Manual for all mounting options.

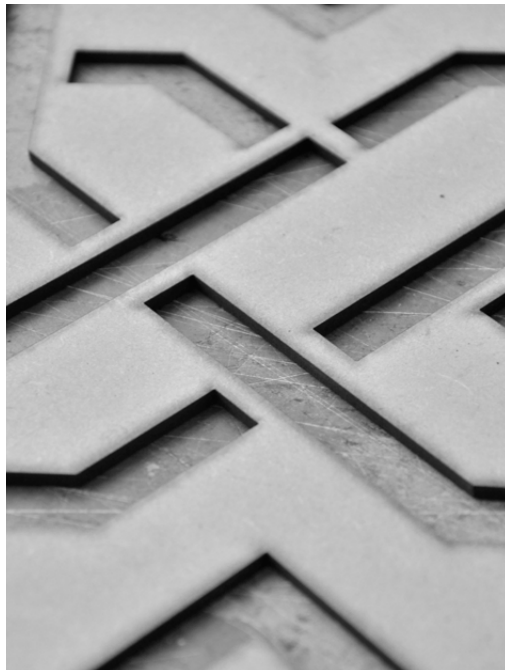

Pintark

GRAPHIC
INSTALLATIONS.

Pintark's graphic installations are personalised or bespoke compositions inspired by standard components.

Our services extend to working with designated installation teams to ensure a complete and successful application of our product.

fulcrum

Radial patterns inspired by Pisco, diverging outwards forming textured discs that break into linear lines. Comprising of arrow double tip block.

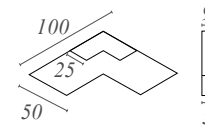

SIZE

750 x 1750 mm
29.5 x 68.75 inch

MATERIAL

Leather - Castagna

COMPONENT

Block - Arrow Double Tip

Refer to our material catalogues for material/finish options

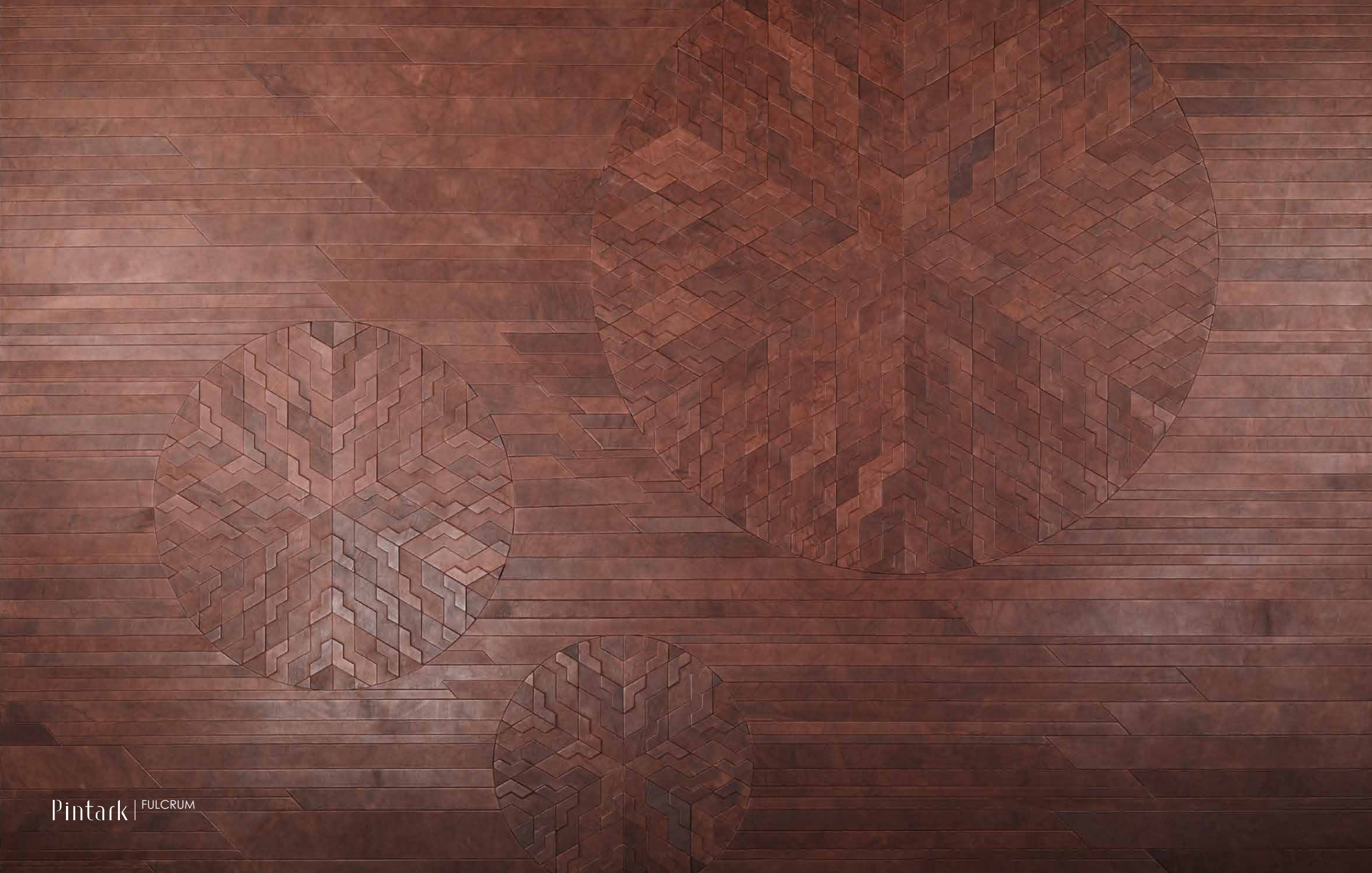

inflight
application

INSTALLATION AT
FOSTER + PARTNERS



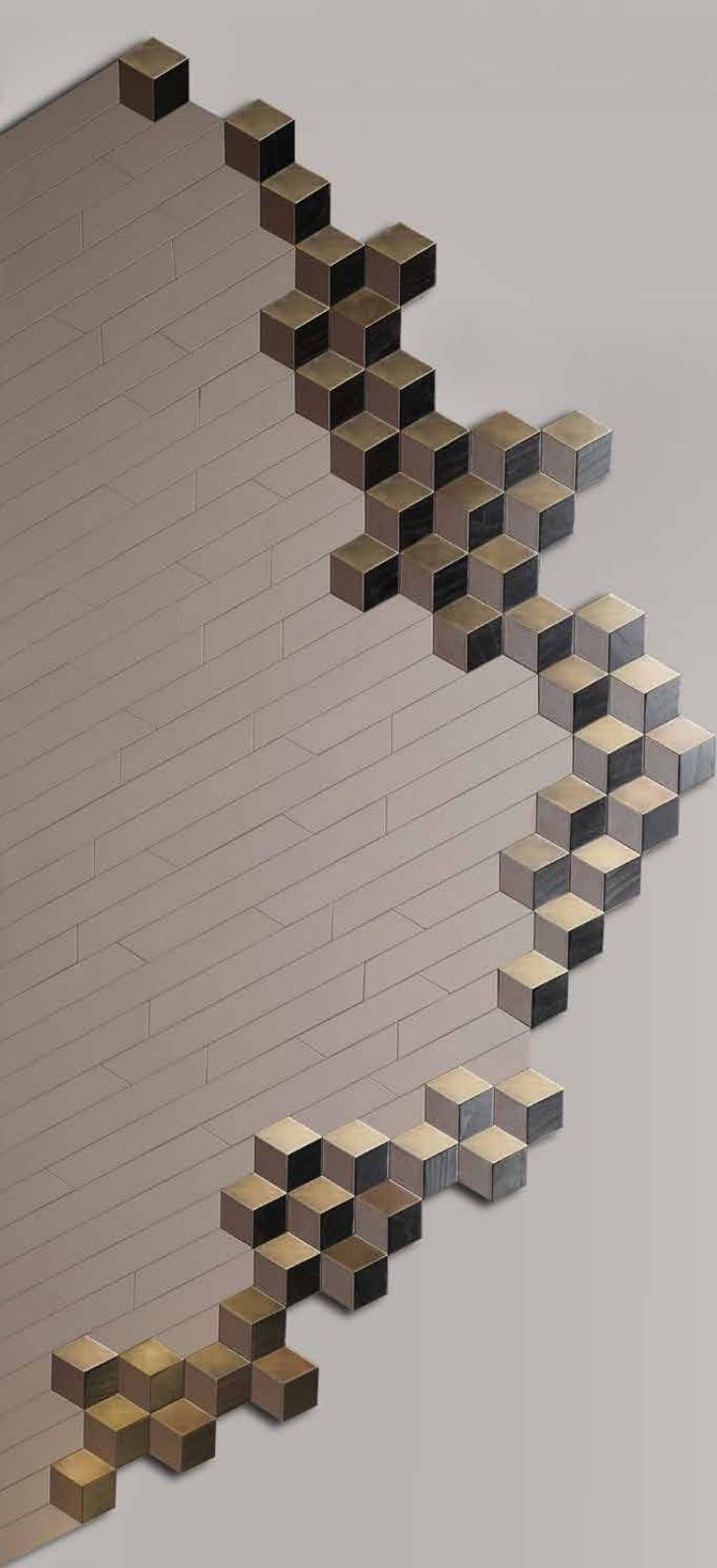

in flight

Using elements from Cuboid, *In flight* creates a dynamic single edged artwork that presents a textural graphic for wall application. Comprising of rhombus flat tile.

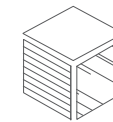

SIZE

900 x 1969 mm

35.5 x 77.5 inch

TECHNIQUE

Embossing: Motif - EM Cord

MATERIAL

Leather - Classic Soft, Pewter

Classic Soft, Cola

Veneer - Fumed Chestnut*

Metal - Medium Brushed Antique, on Brass

COMPONENT

Tile - Rhombus Flat

Refer to our material catalogues for material/finish options

* Commissioned veneer



pixa

Animating the grid through surface and line, Pixa breaks the grid to create it's own form and language. A single edged graphic for wall application comprising of the padded and flat square tiles.

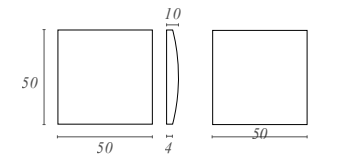

SIZE

750 x 1750 mm

29.5 x 68.75 inch

MATERIAL

Leather - Classic Soft, Nude

Metal - Medium Brushed Antique, on Brass

COMPONENT

Tiles - Square Flat, Square Padded

Refer to our material catalogues for material/finish options



Pintark

ARTWERKS.

Pintark's Artwerks service provides clients with a complete package that delivers bespoke designs from concept to realisation.

We work with architects, developers, designers and end clients such as hoteliers, to create bespoke designs for specific application.

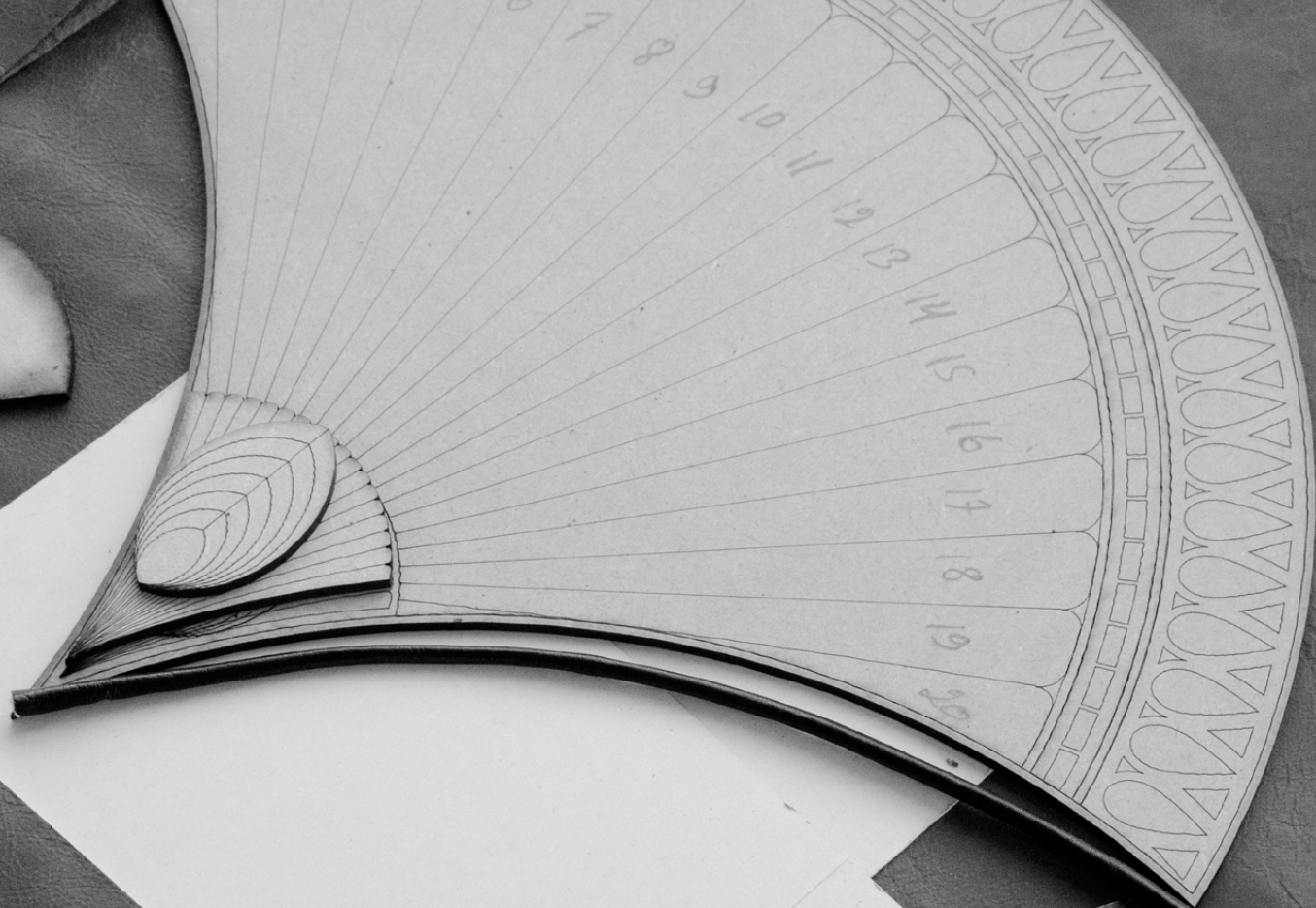



citylights

for Crypton, Las Vegas, US

Pintark's brief from Crypton was to devise a way to present their new collection of cutting edge textile solutions in a manner that brought out their intrinsic beauty and qualities of colour and textured surface.

Using the new fabrics and employing Pintark's techniques in sculptural surfacing, Pintark together with Crypton chose a 'wall' to bring these concepts together.

The walls were a means to create a spatially interactive experience connecting viewers to the fabric's technology of durability, versatility and touchability.

**Crypton was awarded
the best product presentation
of HD EXPO 2014, Las Vegas.**





fracta

*for Raymond Concept Store,
Bangalore, India*

*Developed for Raymond Apparel,
Fracta applies Raymond's signature
apparel fabrics in a new interior context.
Comprising of a triangular geometric
composition punctuated by the brand
colour, Red.*





fossil

*for Raymond Concept Store,
Bangalore, India*

*Created for the Heritage Area of
Raymond's concept store, Fossil is a
wall graphic that applies Raymond
Apparel's heritage fabrics in a new
decorative interior context.*



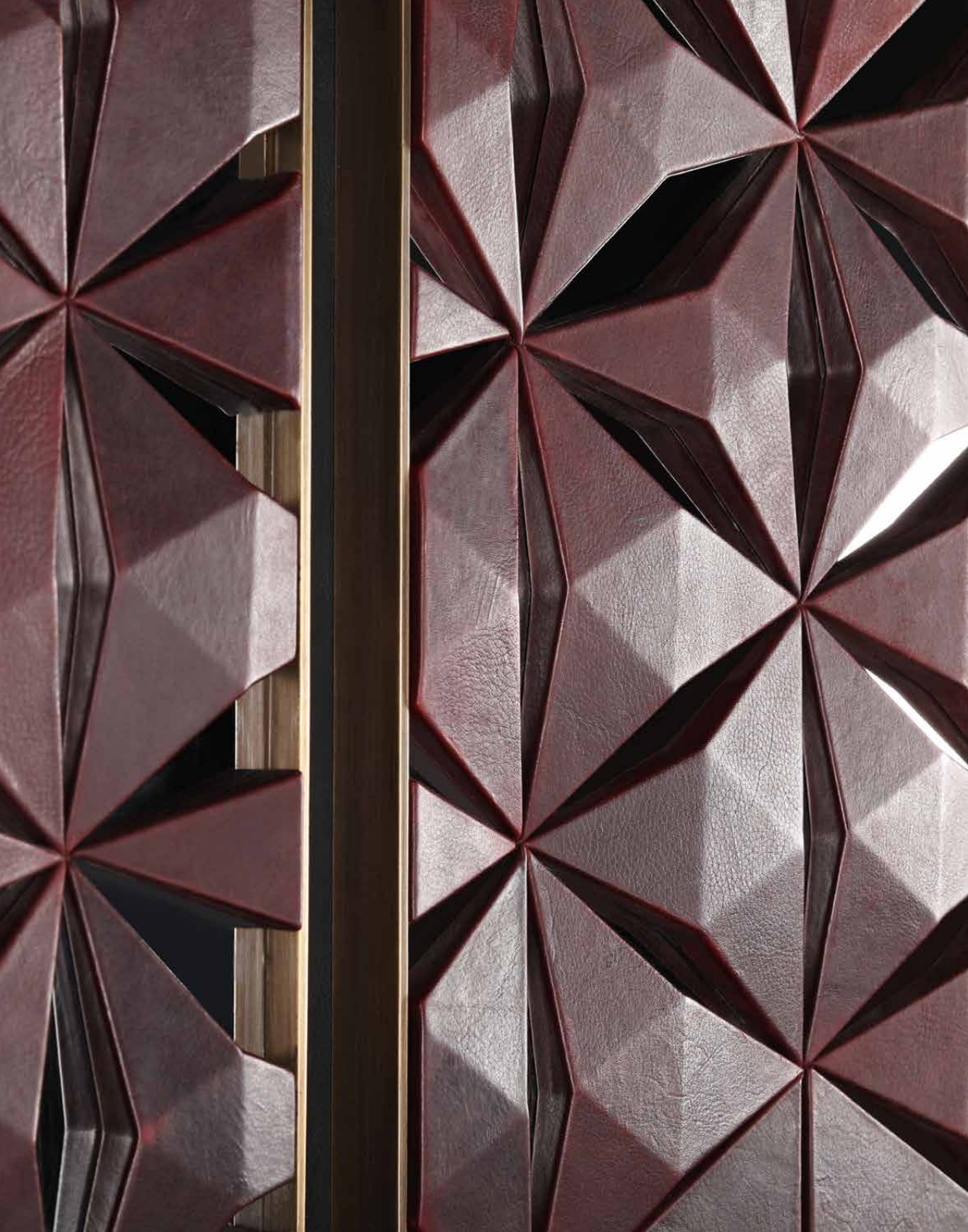

kaeisol

for Pintark

Kaeisol brings to life surface and visual complexity.

A transitional motif creates a soft, crafted surface that celebrates coming together of matte and lustre finishes in a durable tactile form.

The artwork moves from flat to ornate three dimensional form, employing engraved surfacing and material layering.

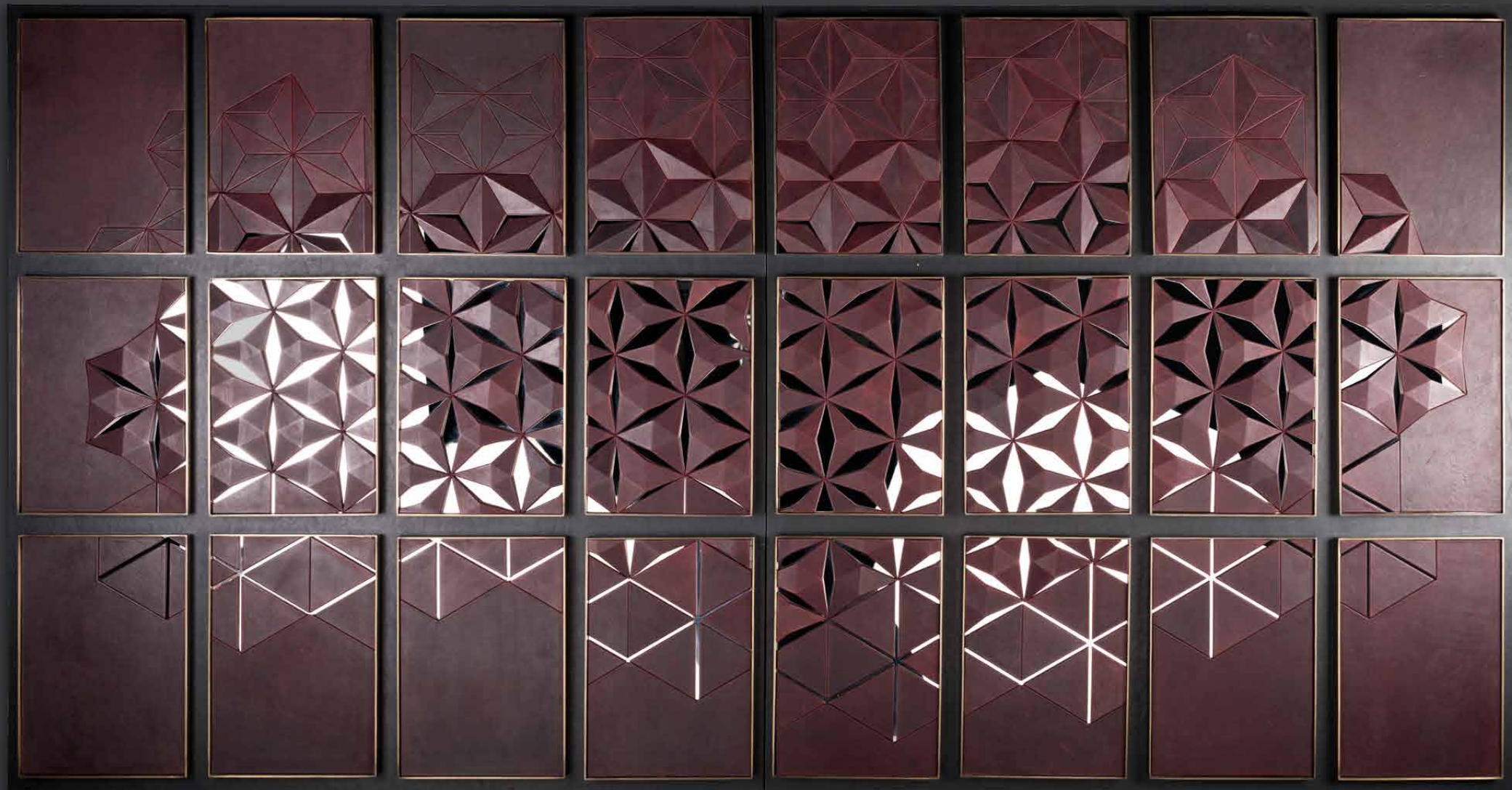



transa

for Pintark

Employing traditional and cutting edge materials, TRANSA is a wall mounted Artwerk that modernises the 'wall panel'. It celebrates material in visual form through the composition of material and detail.

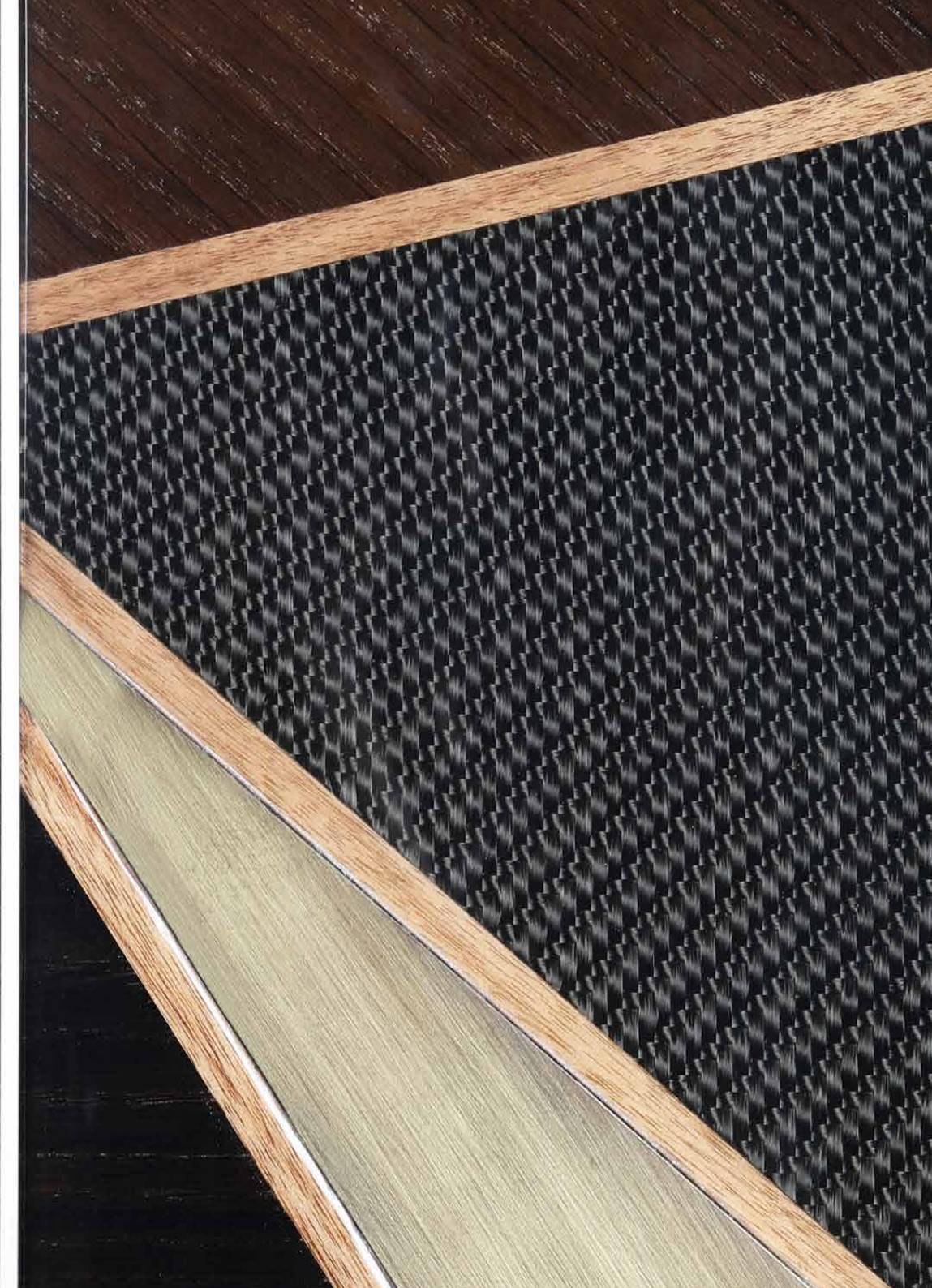
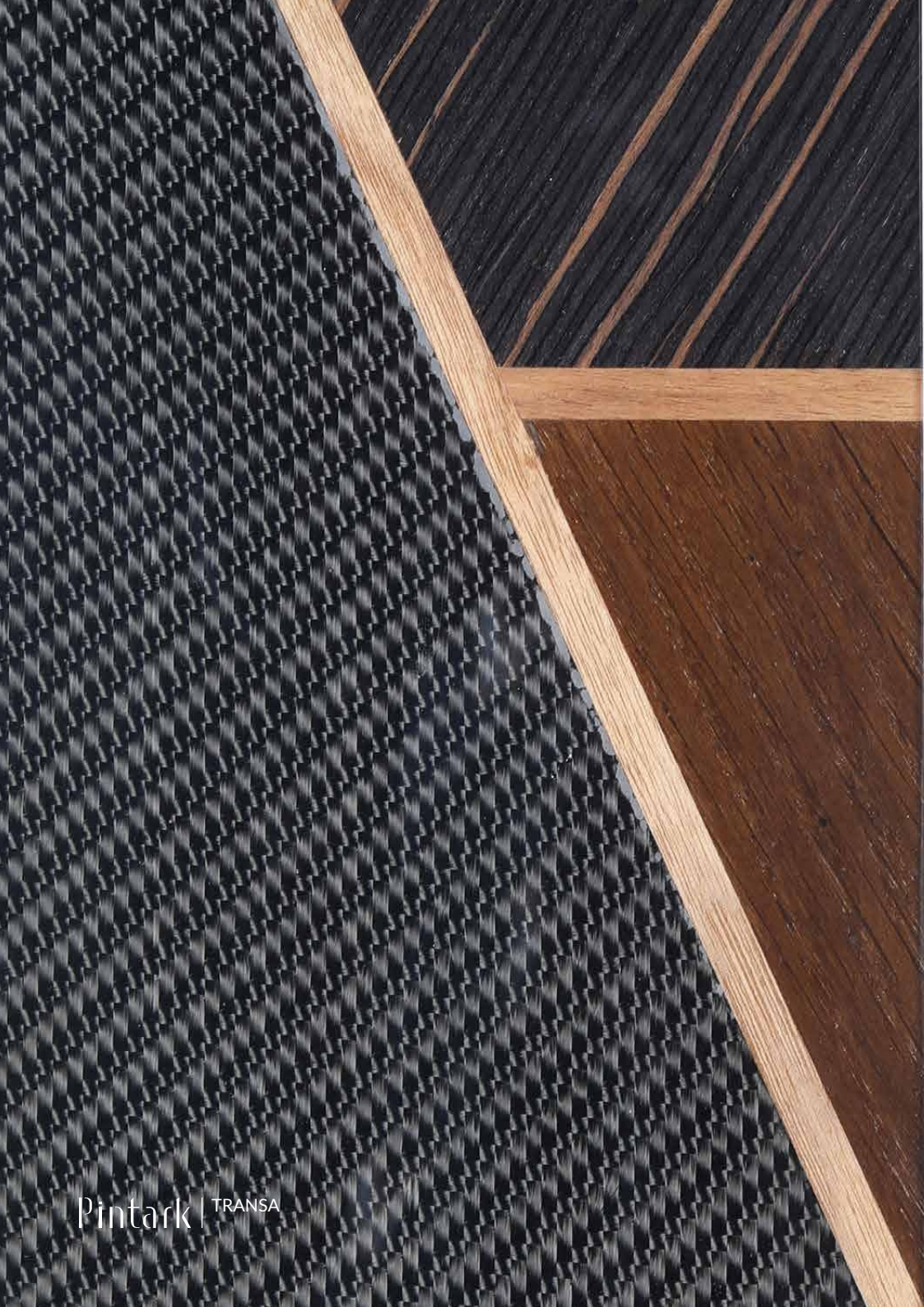

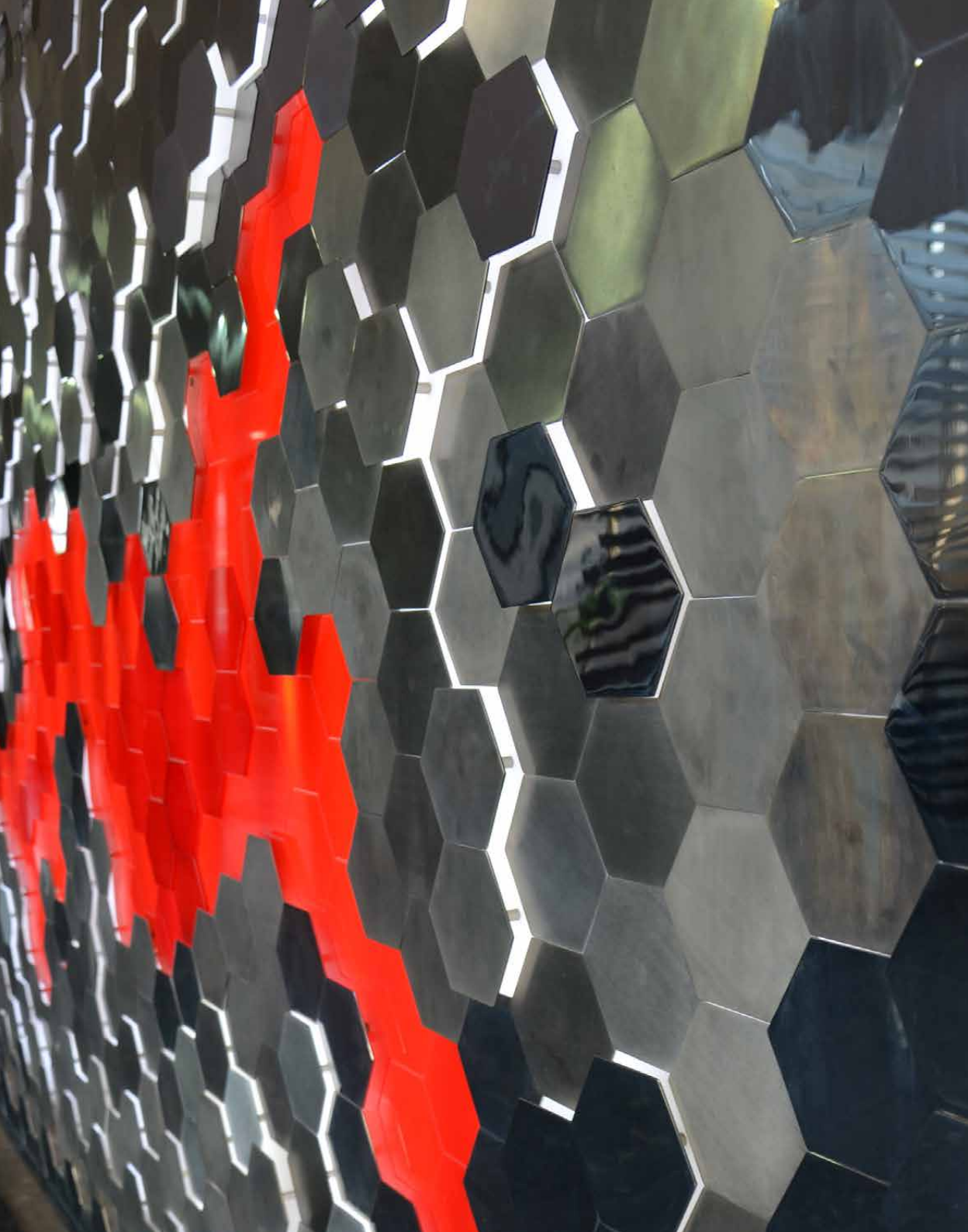

uber bang ::

*for Seimag Corporate Office,
Gurugram, India*

*from molten to solid, changing states
Bespoke surface artwork
reflecting Seimag's activities in
steel manufacturing.*

*The commission comprises of
individually mounted hexagon plates
that create a undulating
back lit surface.*

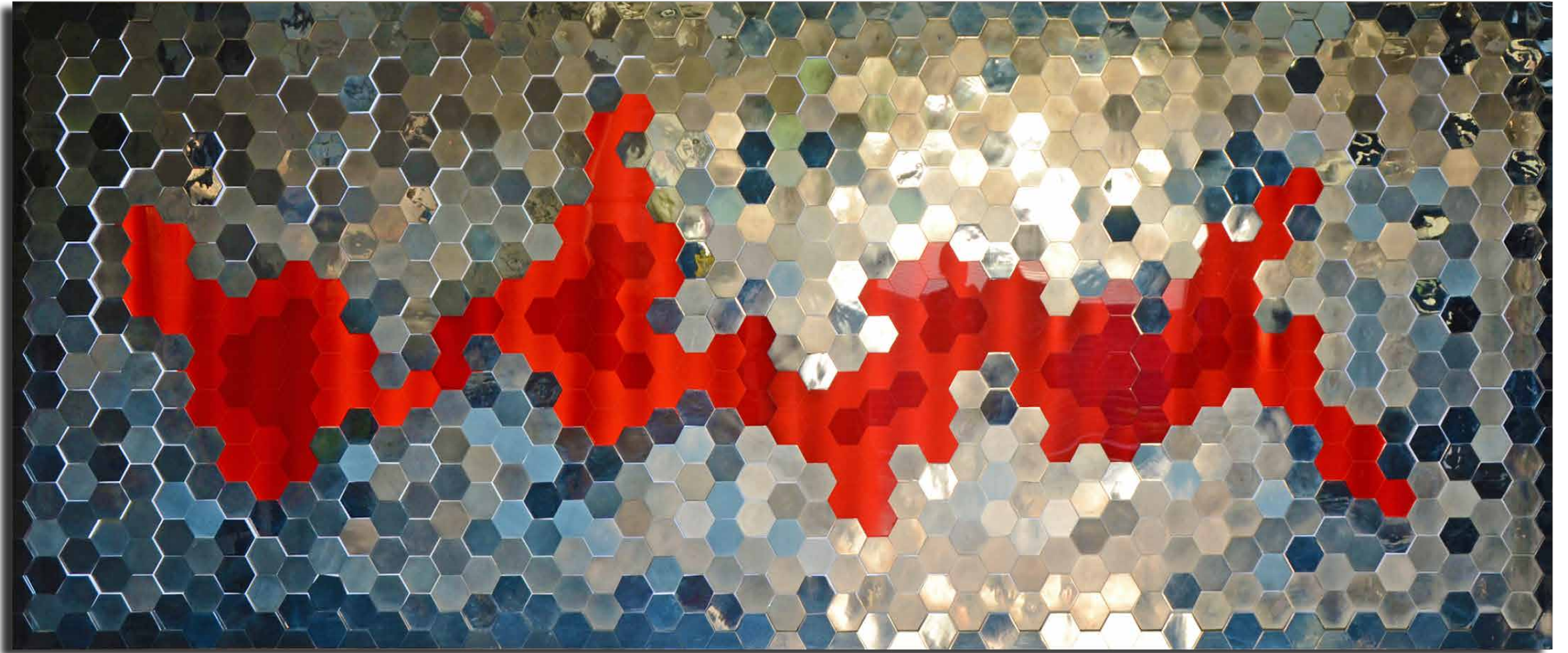



Pintark

TEXTILE
ARTWERKS.

Pintark extends its collaboration with Toucan Krafte to introduce a series of textile artwerks, available as limited edition or commissioned.

Created by hand, each edition is individual, using sourced vintage fabrics. The series employs several hand techniques developed by Toucan Krafte, with each artwerk dedicated to a single technique.

The techniques themselves originating from traditional textile crafts, can be understood as new crafts - creating their own aesthetic and visual identity, from the rigid discipline of Perla to the looseness of Floret, these new crafts resonate with contemporary culture and personality simultaneously.





perla

SIZE

1150 x 1350 mm

45.25 x 53 inch

MATERIAL

Vintage Fabric

**WINNER, Art and Accessories
2017 BEST OF BDNY AWARDS**

Shortlisted for WIN AWARDS 2017



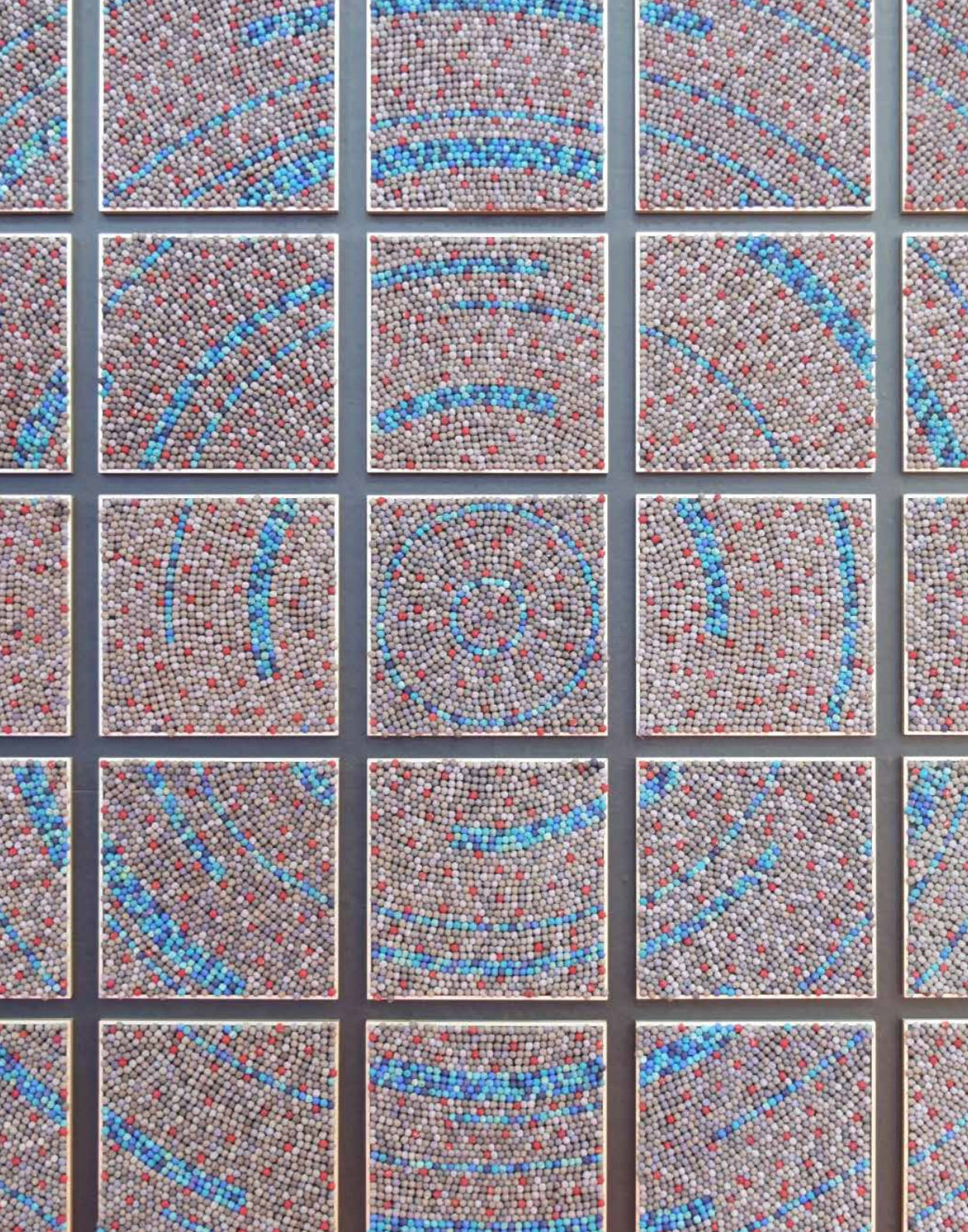

perla circle

SIZE

1150 x 1150 mm

45.25 x 45.25 inch

MATERIAL

Vintage Fabric

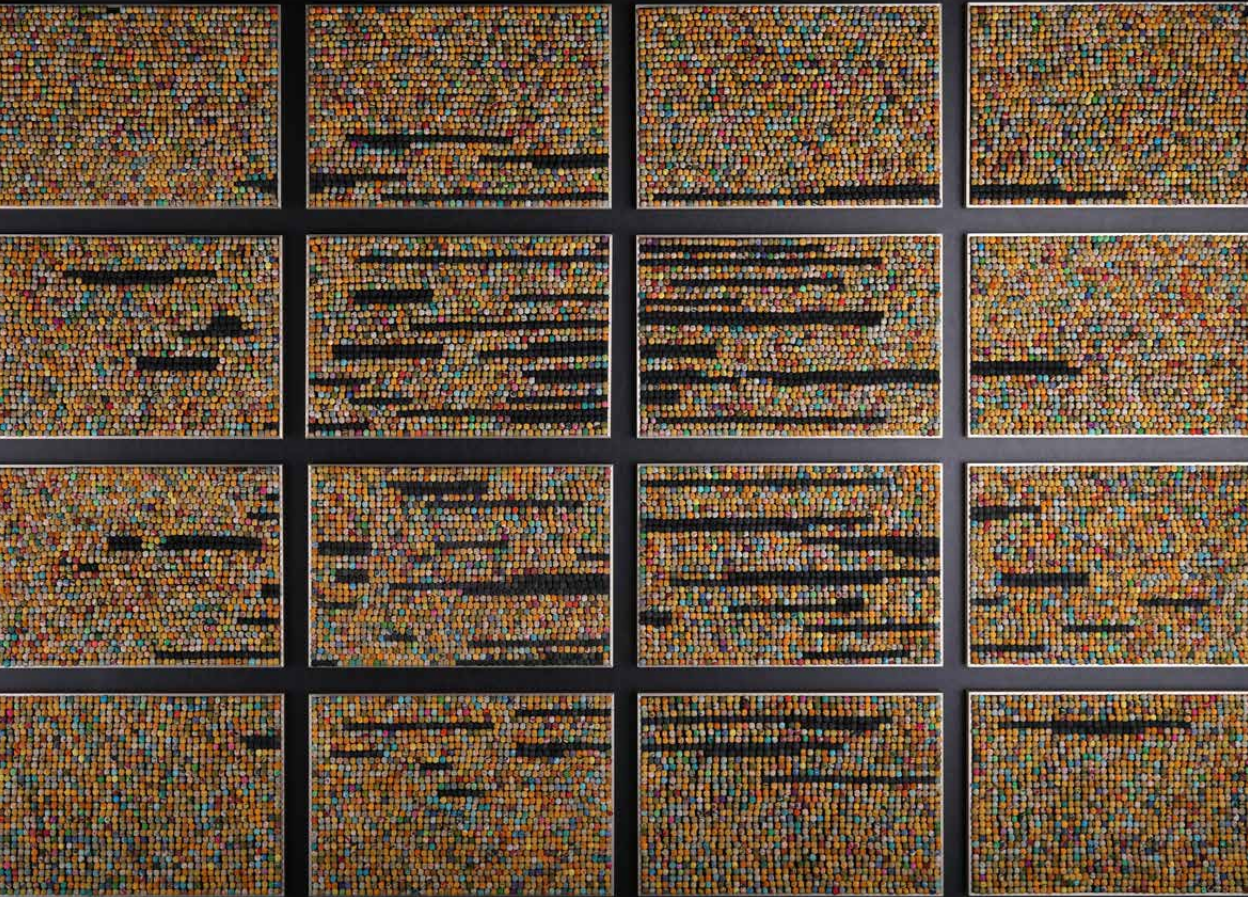

lakeer

SIZE

1275 x 875 mm

50 x 34.5 inch

MATERIAL

Vintage Fabric



phool

SIZE

1150 x 1150 mm
45.25 x 45.25 inch

MATERIAL

Vintage Fabric



shaher:city

SIZE

875 x 1275 mm

34.5 x 50 inch

MATERIAL

Vintage Fabric





floret

Celebrating the beauty and diversity of traditional fabric textiles, Floret is a handcrafted textile surface of layered discs of fabrics. The discs are stitched together to form a loose ruffle, each ruffle hand stitched to form a three dimensional form

SIZE

750 x 790 mm

29.5 x 31 inch

MATERIAL

Vintage Fabric