



IMPROVE YOUR HOME & IMPROVE OUR WORLD

ZANAT

CONTENT

THE STORY OF ZANAT	5
UNIVERSAL SUSTAINABILITY	13
ZANAT: BOSNIAN FOR “CRAFT”	19
PRODUCTS	24
Tables	24
Chairs	56
Benches & stools	74
Storage	90
Accessories	113
DESIGNERS	100
MATERIALS, FINISHES, CARVING TEXTURES	119
TECHNICAL INFORMATION ON PRODUCTS	125

ZANAT

ZANAT

ZANAT



“It takes a tremendous amount of history to make even a little tradition.”
Henry James





THE STORY OF ZANAT

FROM PRIMITIVE VILLAGE CRAFT TO UNESCO WORLD HERITAGE LIST

Zanat was formally launched as a design brand only in 2015 and it has come a long way since. Zanat's roots, however, are to be found much earlier in history. It started more than a century ago when Gano the great grandfather of Zanat's founders, Orhan and Adem Niksic, stumbled upon what once was a primitive hand-carving technique that originated from a small village close to our hometown of Konjic, just south of Sarajevo on the Neretva River. Gano learned the carving technique from some pioneer woodcarver-entrepreneurs who (thanks to visionary educational support of the Austro-Hungarian empire's regime that ruled Bosnia at the time) perfected the village technique beyond recognition and teamed up with already established furniture producers in Sarajevo, such as Buttazoni-Venturini, who exhibited hand-carved furniture pieces at fairs and exhibitions in Milan, Paris (Millennium exhibition of 1900), Vienna.

Gano passed his skills down to his sons Salih, Meho, Adem and Asim. Salih opened the first woodcarving business in the Niksic family in 1919 and trained his younger brothers. Adem, the most entrepreneurial of all, took over the company in 1927 and built a reputable export business. Others soon followed his example, and in the peacetime between the two World Wars, several fine furniture workshops were opened in Konjic, producing hand-carved furniture and decorative objects in local hardwoods. With this legacy as our foundation, our family has been designing and building heirloom-quality hand-carved furniture for more than four generations.

On December 6, 2017, the Konjic woodcarving technique perfected and preserved to a large extent by our family was officially inscribed onto the UNESCO Intangible Cultural Heritage of Humanity list. The quality and uniqueness of traditional hand-carved furniture from Konjic has garnered global acclaim; several pieces produced by our ancestors are kept in the Ethnography Museum in Belgrade and the National Museum in Sarajevo and few pieces are under state protection as part of Bosnia's

national cultural heritage. The unique woodcarving and furniture style developed in Konjic defines Bosnian traditional furniture and interior design.

We can proudly say that our company belongs to the category of European family-owned enterprises that through generations of uncompromising quality and innovation have become symbols of a city and its traditions. But the road to success was not without challenges. World War II and the subsequent advent of socialism in Yugoslavia forced our grandfather and virtually all the woodcarvers in Konjic to close their businesses. And although it was nearly impossible to run a private business during the early years of socialism, Adem's sons Mukerem and Besim reopened the business in 1950s and kept it alive. Then came the end of socialism and instead of greater freedom a series of wars broke out that tore Yugoslavia and Bosnia apart.

The Days of Manulution: Recrafting Modern Design

Besim did not waste time after the Bosnian war ended in 1995. He reopened under the name Rukotvorine and started growing the company with the help of his sons Adem and Orhan. New investments were made and the business expanded quickly. Adem took over management of the company, and he and his brother Orhan developed a new vision for the company, inspired by their appreciation for modern design and their disillusionment with the increasing divorce between modern design and quality craftsmanship. Adem and Orhan decided to promote a new idea in furniture design and production: one that emphasizes craftsmanship and shows how traditional hand-carving techniques can seamlessly blend with and open new possibilities for modern design all while contributing to sustainable socioeconomic development.

The Making of Zanat

Old ideas always evolve and new ones are born, in particular during happy, idle times. Thus, while vacationing during the summer of 2013 on the idyllic Croatian Island of Korcula (where Marco Polo was allegedly born) the idea for Zanat came to life. There, Orhan and his friend Mark Bartolini (an aid worker and hobbyist craftsman who developed a close friendship with Orhan and the Niksic family during the Bosnian war) discussed two of their favorite topics: ways to advance the development of Bosnia, and the arts of furniture design and production. Based on his long experience in international development as a senior economist with the World Bank and other international organizations, Orhan had ideas how to use his family's business as a vehicle to address some prominent market and government failures that hinder economic growth and job creation in Bosnia. Mark, an appointee in the Obama administration, with a lifelong commitment to social justice and the environment, discussed with Orhan





how these economic drivers could be melded with their shared concerns over sustainability, good governance and social justice to create a company that could serve as a model for Bosnia's reemergence in the global marketplace. The idea for Zanat was born and it took off soon thereafter thanks to selfless support and talent of our friends and other people who believed in the idea, like Scandinavian designers Monica Förster, Harri Koskinen, and renown Swedish architect Gert Wingårdh who accepted an invitation to design for Zanat at the inception stage.

Now, at a time when Bosnia is suffering one of the highest unemployment rates in Europe, Zanat is creating opportunity, hiring and training young people. We are breathing a completely new life to this UNESCO listed hand-carving technique, preserving and promoting the craft that used to be close to extinction. Our vision has incorporated a developmental model that seeks to establish Bosnia and the Balkans region as a hotspot in the global designer furniture market and according to the writings of reputable international magazines and newspapers we are already succeeding in that. Our aim is not only to become a known international design brand, but also to demonstrate the highest standards of corporate governance and sustainability. We are committed to making our products with sustainably harvested wood from local suppliers, as we know that Bosnia's abundant forests must be well-managed if succeeding generations are to enjoy both their bounty and their beauty. Zanat is committed to achieving a carbon neutral footprint through product longevity and conservation.

The furniture produced by our grandfather could be found in exceptional residencies and offices throughout South Central Europe. Today, Zanat's furniture is finding favor in a global designer furniture and accessories marketplace. While the designs and scale of our company have, and will continue to, evolve--our company values will not. We are committed to both the satisfaction of our customers and to our traditions. We believe that you, our customer, should feel secure that when you buy a piece from Zanat you are not only improving your home, you are improving our world.

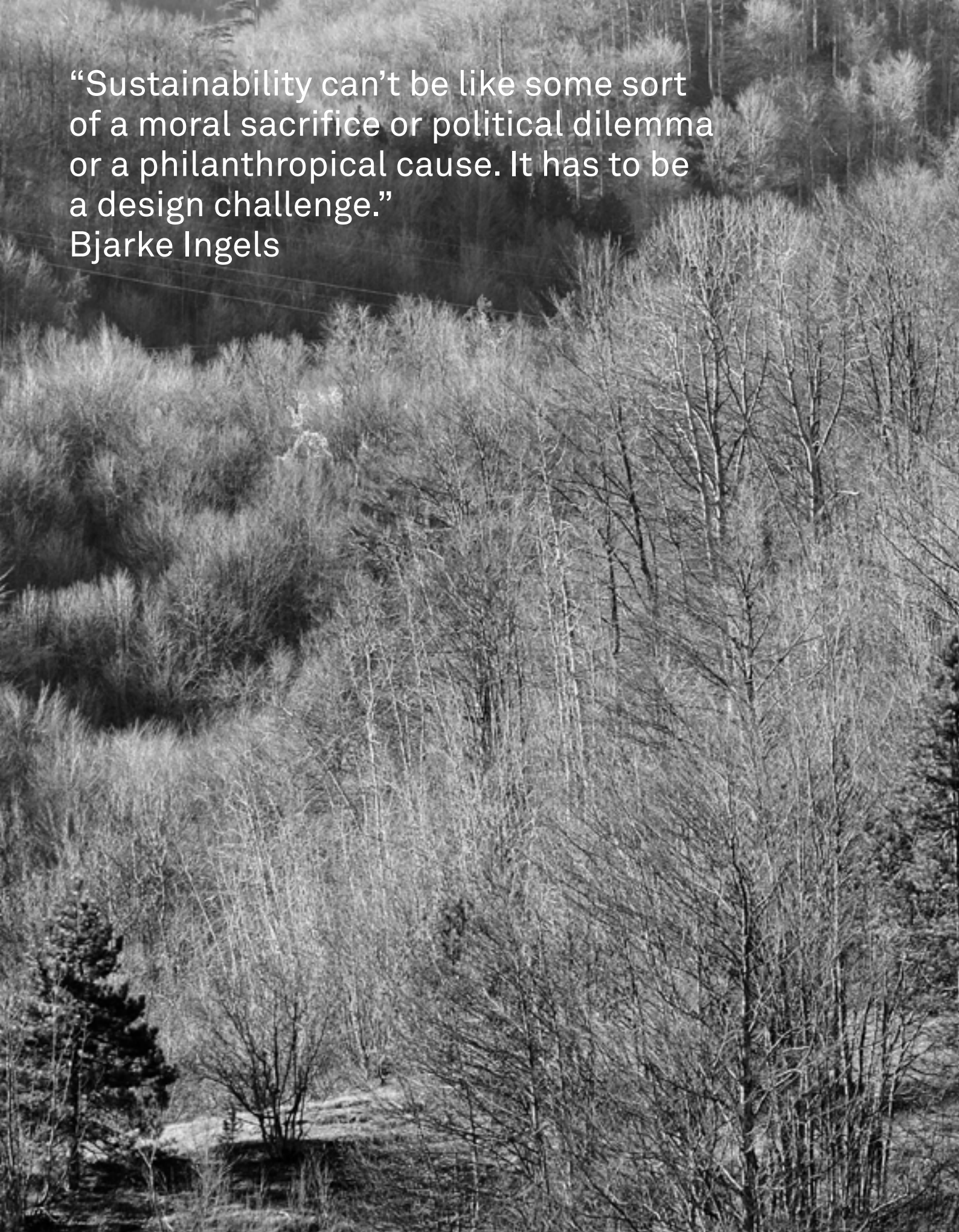
A black and white photograph of a dense forest of bare trees on a hillside. The trees are mostly deciduous and without leaves, showing a complex network of branches. The terrain is sloping upwards from the bottom left towards the top right. The lighting is somewhat flat, creating a range of greys and blacks.

“Sustainability can’t be like some sort of a moral sacrifice or political dilemma or a philanthropical cause. It has to be a design challenge.”

Bjarke Ingels





UNIVERSAL SUSTAINABILITY

Sustainable Impact on Environment, Humans and their Communities

From the moment the idea for Zanat first slipped into conversation over strong Bosnian coffees and a cool breeze off the Adriatic, the concept for the company has been much more than quality furniture design and production. We imagined a firm that took the same attention to detail that goes into making the perfect joint, and applied it to all aspects of the business in service of improving not only our customers' homes but also their world. We call this practice Universal Sustainability, because we want the effect of every significant action that we as a business take to be sustainable. In other words, we'd like to see "Corporate Social Responsibility" taken to the next level.

The Human Element

We believe that what we do will be "universally" sustainable if the effects of our actions on our entire ecosystem—including humans and their communities, be they local or global—serve as improvements to that ecosystem in both the short and long-term. With that in mind, we ask ourselves not only what effect our actions will have on the physical environment, but also on other forces and systems that affect the quality of life for individual people and communities. We want our actions to contribute to and facilitate sustainable socioeconomic development. Zanat's design strategy and identity takes into account not only product-specific and market-specific variables, but also the impact of design—through the production process--on sustainability in the widest sense. At Zanat, we practice what we preach in part by creating jobs for craftsman and university graduates, offering continuous training to all employees, and paying better-than-average living wages. We will soon be launching a woodcarving academy in partnership with some educational institutions. By training our staff for greater opportunities and paying our workers what they're worth—not simply what we could get away with—we ensure that we not only have the best craftsmen and women creating our products, but that our entire community benefits as well. Our "living" wages don't force workers to scrape by. They allow families to invest in themselves, putting children in school and books on shelves, fixing up homes and purchasing useful technology, and ensuring access to healthcare. We are also committed to serve as a marketing

and knowledge-transfer platform for smaller craftsman and producers with outstanding products and business ethics, but who don't have access to capital or knowhow to export; by doing this we will be correcting well-established market and government failures. All of these benefits guarantee that with each person we employ—directly or indirectly--the region as a whole improves its prospects. And in a region only two decades removed from a brutal war, combating a nearly 30 percent unemployment rate with jobs that can support whole families means a more secure world overall.

What's more, our unique hand-carving techniques are undoubtedly a defining characteristic of our local Bosnian community's cultural heritage—the recent inscription of Konjic woodcarving onto the UNESCO Representative List of Intangible Cultural Heritage of Humanity testifies to its importance—and through our efforts to integrate these techniques into modern design we are not only able to create better jobs, we are helping preserve the community's traditions and promoting a design trend that puts human welfare center stage.

Direct Impact on the Environment

Of course, any effort to support the communities we live in must be grounded in a commitment to minimize direct impact on the physical environment that supports us all. At ZANAT, we do a number of concrete things to protect and improve our environment and details can be found on www.zanat.org. Zanat's products are designed to minimize the impact on environment and human welfare through rational use of sustainably sourced natural materials and long product life.

Leading by Example

We are not naïve so much to think that our company alone can change the world, but we are optimistic enough to believe that if we can prove that the way we do business works—that it is sustainable—others will see the potential and join efforts to change the way business will be done tomorrow. In the end, Universal Sustainability is a simple concept: look into the most basic aspects of your business and ensure that you are proud of their impact on the company, the customer, and the world. We are proud of what we do at Zanat, and we have confidence that we can inspire others to join and do the same.



“Craftsmanship names an enduring,
basic human impulse, the desire
to do a job well for its own sake.”
Richard Sennett, *The Craftsman*







ZANAT: BOSNIAN FOR “CRAFT”

Craftsmanship is the essence of our company's identity. Our very name, Zanat, is Bosnian for “craft”, and the artistry and skill that it implies is also vital for fulfilling our mission of Universal Sustainability.

There are many reasons why we still sketch new designs directly on wood surfaces, manually chiseling and cutting the grain to bring the drawings to life, but we would be lying if we didn't include the sheer fun of woodcarving, and a certain emotional attachment to the hand-carving techniques used by four generations of our family on the list as well. The number of textures, patterns and aesthetic styles that can be created by using these techniques is infinite, limited only by the imagination of the artist-creator. The process enhances the tactility of wood pieces and transforms them into traditional or modern decorative art and since the details are done by hand, no two pieces are exactly the same—quite the opposite of today's mass produced and homogenized consumer goods. Unsurprisingly, the creative and remarkably unique designs that emerge from our manual production techniques are fertile sources of new inspiration to both novice and renown furniture designers.

Several of our products and the carving technique are a part of the official Bosnian cultural heritage list. The woodcarving technique specific to Zanat's hometown Konjic, which is still practiced in our company was inscribed onto the UNESCO Representative List of Intangible Cultural Heritage of Humanity. We take pride in being the bearers, protectors and promoters of this unique heritage for the whole world.

Still, beyond beauty, love of the process itself, and a responsibility to the survival of our culture, there are other important reason why we espouse hand-carving and craftsmanship in general. One of them is to restore some tactility—an essential human need—to an increasingly virtual world. Furthermore, in today's world of accelerating automation, which is driven by technological advances, millions of people in all sorts of industries are losing jobs to computers and machines around the world. Identifying strategies to create decent employment opportunities for the global army of about 200 million unemployed individuals with manual

or even mental skills is one of the top conundrums facing policymakers, researchers, and international development professionals. At Zanat, we believe firmly that technological advancement is overall positive and not a process we're interested in trying to stop, but we also believe that the kind of jobs we can train for and offer will form a part of the solution for automation's side effects. The marriage between modern product design and craftsmanship—which we use to great effect everyday—was basically a case of divorce after the industrial revolution, but we think we have found a way to bring back the love and to help the entire family. Back then, the change in design trends enabled industries to develop, created jobs in those industries, and produced goods at prices the masses could afford. Now, too few people are producing too many products and those who don't work cannot afford them. Re-kindling the marriage between design and crafts not only provides new inspiration to design professionals, but also contributes to resolving one of the most troublesome socioeconomic problems of our time: unemployment. In Bosnia, where a quarter of the labor force is unemployed—and more than a half of young people—the creation of quality jobs is certainly an imperative.

In short, ours is a kind of craftsmanship that embraces and holds on to rich traditions, while at the same time reaching out confidently toward the future. It is the kind of craftsmanship that can both improve your home and our world.











Unna Table

Designed by Monica Förster

Unna Table is an elegant multipurpose table that is super lightweight even though it is made entirely in solid wood. It comes in fixed and extendable versions. What distinguishes the extendable version of the table in addition to its overall sleek design are lace-like hand-carved table top extension leaves, which are inserted in the middle of the table. The designer, Monica Förster, applied Zanat's UNESCO nominee hand-carving technique to create these unique and customizable extension leaves that can match the color of the table frame or come in a contrasting color. The table can be extended by 50 cm with one and 100 cm with two extension leaves, both conveniently stored underneath the table top. The extension leaves are sold separately and one can always order extra ones in a different color or with new carving patterns. The handmade extension mechanism made in steel and wood is custom-designed, very simple to use and built to last.



Touch Table

Designed by Studioilse

Touch Table designed by Studioilse is part of the Touch Collection. The special quality of these products lies in the hand-carved surfaces that engage our instinctive impulse to feel something and reflect our hunger for more tactile surroundings in the digital age. The table is hand-made in Bosnia Herzegovina using Zanat's wood carving skills, which were added to the UNESCO Intangible Cultural Heritage of Humanity List in December 2017. The carvings on the table top make it uniquely tactile and they take three man-days to execute. Since the craftsmen carve the pieces at random, without drawings – each piece is unique as no two carved surfaces will ever look the same. The table is deliberately designed narrower to create a cozy and intimate dining atmosphere. Despite what some might perceive, the table surface is easily cleaned with a sea sponge or other soft cleaning cloth.







Neron Table

Designed by Monica Förster

Neron dining table is a story of simplicity with strong character. The light table top rests on a robust, but simple and elegant structure. The table looks beautiful from any angle, even from underneath. Skillfully executed by Zanat's master craftsmen, carving patterns on the table legs represent the essence of the table's character. The patterns can be customized and each pattern gives the table a specific persona. It comes in three standard dimensions, five different species of wood in natural wood color or stained. The table can be disassembled and is suitable for both residential and commercial use.





Branchmark (3) Table

Designed by Gert Wingårdh & Sara Helder

The idea behind this table is to celebrate the joy of vertical forces by the remarkably stable wonder on three legs. One of the three legs is branching for added sturdiness and character. Leg endings, one of them hand-carved, create playful marks on the surface of the table top. The arts and craft is celebrated through the hand-carved Unicorn leg.





Branchmark (8) Table

Designed by Gert Wingårdh & Sara Helder

In Branchmark (8) Table the dance of legs is created to celebrate the joy of vertical forces. Leg endings, one of them hand-carved, create a “cool” expression on the table top. The arts and craft is celebrated through the hand-carved Unicorn leg. Branchmark (8) Table is the winner of the Interior Innovation Award 2015.



Branchmark (4) Table

Designed by Gert Wingårdh & Sara Helder

The original Branchmark (3) and Branchmark (8) tables (Interior Innovation Award winner that celebrate the joy of vertical forces through the dance of table legs) got new companions in Branchmark (4) and Branchmark (0). Branchmark (4) is a rectangular table that comes in four different standard sizes. The table has four conus-shaped legs, which give birth to two thinner branches close to the table top, which makes not only a nice design detail, especially since both the main branches and the thin branches penetrate the table top to leave playful markings on the table top surface as an attestation of fine craftsmanship. Without a frame and with chamfered edges the tables have a light, but imposing appearance. This table is available in walnut, cherry, maple, ash and oak.







Branchmark (O) Table

Designed by Gert Wingårdh & Sara Helder

The original Branchmark (3) and Branchmark (8) tables (Interior Innovation Award winner that celebrate the joy of vertical forces through the dance of table legs) got new companions in Branchmark (4) and Branchmark (O). Without a frame and with chamfered edges the tables have a light, but imposing appearance. Branchmark (O) is the round version of Branchmark (4). The smaller versions (100cm and 120cm diameter) come with three conus-shaped legs with branches while the large one (150cm diameter) rests on four legs with branches. Unlike many frameless tables, Branchmarks are all rock firm and stable, a credit to the mastery of knowledge on static forces at Wingårdhs architecture practice. Available in walnut, cherry, maple, ash and oak.



Daisy Table

Designed by Salih Teskeredzic

The inspiration for this product was found in nature and turned into an abstract form through design. Memory, the central topic of this work, defines the product's origin and its unique identity in the transformation of old into new and traditional into hand-crafted modern. Daisy's exquisite table top features hand-carved floral motifs (optional) and hand-carved edges, which create an illusion of enigmatic composite material. Its legs can be made in wood or stainless steel.

Daisy Table was awarded the Interior Innovation Award 2011.







Wave Table

Designed by Salih Teskeredzic

The design for this undulating table was inspired by the flow of Bosnia-Herzegovina's Neretva River after an autumn torrent. The hand carved flowers on table top hide built-in storage compartments, perfect for holding candles, spice shakers, snacks and everything else you'd like on-hand but out of sight. Wave Table accommodates eight people.



Touch Console

Designed by Studioilse

Touch Console is part of the Touch Collection that also includes: Touch Bench, Touch Sideboard, Touch Table, Touch Lamp, Touch Side Table, Touch Stool and Touch Tray. The special quality of all Touch collection products lies in the hand-carved surfaces that engage our instinctive impulse to feel something and reflect our hunger for more tactile surroundings in the digital age.











Nera Coffee & Side Tables

Designed by Monica Förster

Nera Coffee & Side Tables are a part of the Nera collection that also includes stools and bowls. The tables consist of a colored glass table top and a sculptural hand-carved base made in solid European hardwoods. The choice of different carving patterns, woods and finishes enables one to customize the product. The tables are suitable for use in both residential and commercial/public settings.









Bowlkan Table

Designed by Harri Koskinen

Bowlkan Table integrates table design with that of wooden bowls to create a single product: a unique coffee table with enhanced functionality. Hand-carved decoration on the bowls seamlessly blends into the soft and minimalist overall expression of the table. The chic Balkan coffee culture now has a companion.



Ombra Table

Designed by Jasna Mujkic

The top of the Ombra Table is constructed by joining together tiny “Penrose Prototiles” in solid walnut. These specific prototiles are named after Sir. Roger Penrose, a famous British mathematician who first investigated them in 1970s. The prototiles have remarkable geometric and visual properties. For one, they are aperiodic, meaning that a shifted copy of the original set of prototiles will never look the same. The pattern does not repeat!

The designer joined the prototiles in the table top in a way to create an abstract tree shade. Ombra Table is made with environment in mind by utilizing small pieces of wood likely to end up as production waste. Ombra Table was awarded the Interior Innovation Award in 2012.



Daisy Side Table

Designed by Salih Teskeredzic

This beautiful small table can be used as a coffee table or a side table. The inspiration for this product was found in nature and turned into an abstract form through design. Daisy is an attempt in the re-birth of handcrafts and an awakening of interest in modern, hand-made products. The table top features hand-carved edges.









Sana Dining Chair

Designed by Monica Förster

Sana is a femininely elegant and extraordinarily light dining chair made entirely in solid wood. The most special feature of the chair is its finely sculpted and multi-dimensionally curved backrest that instills a warm hug effect and provides excellent seating comfort. The outer side of the chair's backrest is entirely hand-carved with carving patterns which were designed to emphasize the curved shape of the backrest and to give Sana the character of a modern hand-crafted object. Sana is a stackable chair suitable both for residential and commercial use. It comes in different color combinations of the frame, backrest and seat.

Disclaimer: The photos shown on this page are of a Sana chair prototype. Small modifications to design were made just before this catalogue went to print. Please contact Zanat for photos of the production-ready version.





Igman Dining Chair

Designed by Harri Koskinen

Igman dining chair is soft and lightweight chair that combines a solid wood frame and a removable soft seat & backrest upholstered in either vegetable-tanned 2.2mm thick saddle leather or a choice of fabrics. The chair comes in a version without armrests and with armrests. The hand-carved details on the flat-cut surfaces of the armrests and the back beam add to the chair's character and tactility.







Unna Chair

Designed by Monica Förster

The idea is a chair with soft, minimalistic, yet humanistic expression. The chair has a thicker seat and backrest, made from solid wood sections. The chair can be individualized by applying Zanat's exquisite carving techniques. Finding inspiration in nature, we have modernized the carvings, preserving, however, the genuine technique. The carvings on a light wood chair can be stained creating a modernist expression, but also an additional way to individualize the product. For a better comfort a molded cushion in leather is used.

Unna Chair is the winner of the Interior Innovation Award 2015 and Golden Chair Award.



Se_Go Chair

Designed by Salih Teskeredzic

Made entirely in solid wood, Se_Go draws inspiration from some mid-century modern design. While a chair of elegant „moulded“ design like Se_Go would not be unusual if made in plastic or metal, this design challenges the limits of furniture design in wood, opening the door for new elegant sculptural designs unseen before in this material.





Quiet Chair

Designed by Jasna Mujkic

Quiet chair is the story of proportion. Every line of this chair is part of a bigger picture of a hermetic structure of proportions. In that sense, the object is a fragment reflecting a whole that is not visible but is strongly felt. The identity of this chair is not expressed at its surface with a line or style, but far behind in the structure of spatial relations. Thanks to its classic elegance, Quiet Chair has the ability to carry hand-carved motifs with no conflict between form and the decoration that consists modernized and customizable carving patterns.









Dama-T Lounge Chair

Designed by Ludovica + Roberto Palomba

Dama-T was designed as a lounge chair to be crafted in solid wood. Essential to its character are checkered hand-carved patterns on the seat and backrest which give it the full flavor of a contemporary object. Dama is inspired by archaic knowledge and the ingenuity of those objects of local culture that irresistibly seduce us in our travels.





Unna Lounge Chair

Designed by Monica Förster

With soft, elegant lines, Unna lounge chair was designed to impart a feeling of softness and comfort to a lounge chair made entirely in solid wood, a warm but hard material. Unna's complex sculptural shape is also a testimony about the extraordinary skill of Zanat's craftsmen in carpentry. The modernized hand-carved patterns--made by applying Zanat's century old and UNESCO world heritage nominee hand-carving technique--add a special touch to the backrest of the chair. The carvings also provide a way to individualize the chair. To provide additional comfort, Unna lounge chair can be ordered with a removable leather cushion on the seat or fixed cushions on the backrest and the seat.





Igman Lounge Chair & Igman Ottoman





Igman Lounge Chair & Igman Ottoman

Designed by Harri Koskinen

Igman Lounge Chair is companion of the Bowlkan coffee table designed to provide the comfort that enables a drift into the uninter-ruptable state of coffee-culture idleness. The softly rounded structure in solid wood with hand-carved edges of the armrests creates a feeling of warmth and a strong, yet unassuming character. The chair is also available without armrests, upholstered in tanned saddle leather and a choice of fabrics.

Igman Ottoman was designed to follow the typology of the Igman lounge chair and it complements the chair both visually and in terms of providing the additional comfort that enables one to easily doze off without needing a bed. The ottoman can also be used for sitting, while two or more ottomans can be combined into a bench system.



Touch Bench

Designed by Studioilse

To touch is both to feel physically and sense emotionally. Touch benches, designed by Studioilse, have a special quality lies in the hand-carved surfaces that engage our instinctive impulse to feel something and reflect our hunger for more tactile surroundings in the digital age. These universal benches are hand-made in Bosnia Herzegovina using Zanat's wood carving skills, inscribed onto the UNESCO Intangible Cultural Heritage of Humanity list. The carvings on the benches take almost two man-days to execute and – since the craftsmen carve the pieces at random, without drawings – each bench is unique as no two carved surfaces will ever look the same. Touch Bench is available in wood or cast bronze legs.







Nera Stool

Designed by Monica Förster

Made entirely in solid wood, Nera stools are characterized by simple and tender sculptural beauty. They come with several different hand-carved patterns which enhance the stool's tactility and each carving pattern gives a distinct character to the stool. The stools look like pieces of decorative art, but are also highly functional. They are perfect for seating in a lounge setting, but can also be used as side tables and can be added as extra seats at a dining table. The stools come in black-stained maple and ash or oil-finished European walnut.



Touch Stools

Designed by Studioilse

Touch stools (side tables), designed by Studioilse, come in "Pill" and "Half Moon" versions. The special quality of all Touch collection products lies in the hand-carved surfaces that engage our instinctive impulse to feel something and reflect our hunger for more tactile surroundings in the digital age. The carvings on stool tops make them uniquely tactile and since the craftsmen carve the pieces at random, without drawings – each piece is unique as no two carved surfaces will ever look the same. The stools can be used in a multitude of different settings: casual seating, around a dining table, as side tables...





Tattoo Stool







Tattoo Stool

Designed by Gert Wingårdh & Sara Helder

Tattoo stool is a neat, light, stable and stackable stool with beautiful and playful carvings, available in a three- or four-legged version. The wholes made in different shape through the stool top make carrying the stools easy. The stools can be tattooed from head to toe or in a very discreet way. They can be chosen in different types of wood, colors, stained or lacquered. Symbolism/stories of the graphics are to be created in the eye of the beholder. For the designers, tattoos are about the contrasts in life, love, joy, sorrow and pain.







Tattoo Bar Stool

Designed by Gert Wingårdh & Sara Helder

Zanat's popular Tattoo stool designed by Gert Wingårdh and Sara Helder is getting bigger siblings in elegant Tattoo barstools, a medium high one (60cm) and a high one (75cm). Like their smaller cousins, the Tattoo barstools come in carved and plain versions. Plain versions have slimmer arch-like leg endings at the top of the stool. In both versions, the legs penetrate the stool tops, leaving perfectly joined and attractive cross-like markings. The first two carved versions of the barstools carry a peacock and pheasant tattoos. The stools are stackable and some versions come with a hole in the middle of the stool top for easier handling.

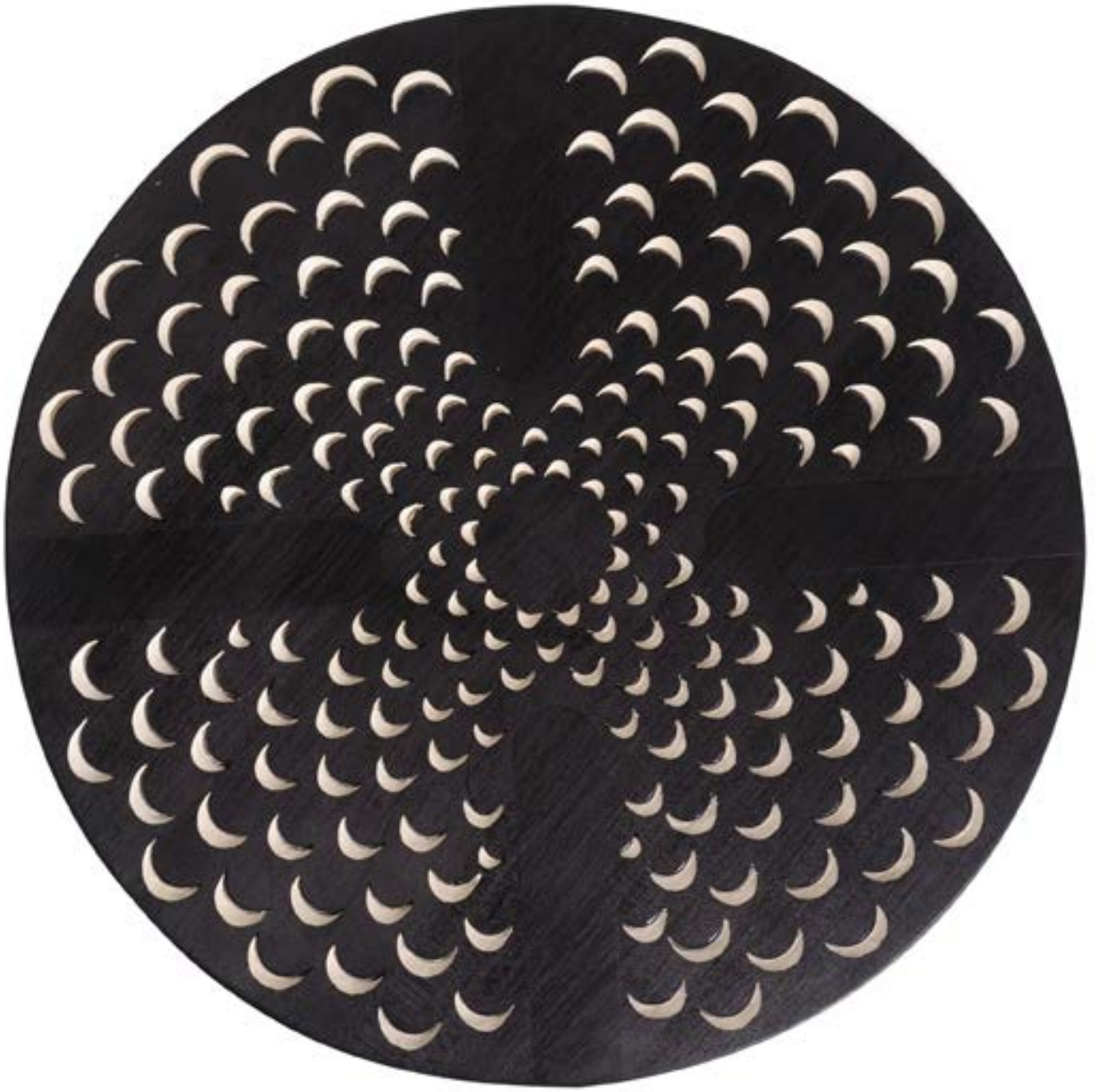





Quiet Stool

Designed by Jasna Mujkic

As a part of the Quiet collection, this small stool is intended for a variety of purposes. The hand-carved motif was designed and made in a way to give the stool a special, pattern building purpose. When one makes a line-up of these stools, the hand carved motifs of adjacent stools match up and create what visually becomes a single piece.



Touch Sideboard

Designed by Studioilse

Touch Sideboard designed by Studioilse is a part of the Touch Collection that also includes: Touch Bench, Touch Table, Touch Console, Touch Lamp, Touch Side Table, Touch Stools and Touch Tray. The special quality of these products lies in the hand-carved surfaces that engage our instinctive impulse to feel something and reflect our hunger for more tactile surroundings in the digital age. The sideboard is hand-made in Bosnia

Herzegovina using Zanat's wood carving skills, which were added to the UNESCO Intangible Cultural Heritage of Humanity List in December 2017. The carvings on the sideboard take three man-days to execute and – since the craftsmen carve the pieces at random, without drawings – each piece is unique as no two carved surfaces will ever look the same. The sideboard comes in three and four-door versions and can be mounted on 42cm or alternatively 28cm X-shaped wood or cast bronze legs. Each door hides a separate storage compartment, with a removable tray-like shelf placed mid height.





Tara Shelving System

Designed by Monica Förster

This shelving system can be used as single units or as a family for a range of interior design wants. The shelves work equally well positioned against a wall or as room-dividers. In addition to creating a versatile and functional piece, the aim has been to show the exquisite craftsmanship of Zanat in the fine joinery and to utilize their unique hand-carving techniques. Tara Shelves was selected for the Interior Innovation Award 2015.







Vinko Wine Cabinet

Designed by Harri Koskinen

The primary objective behind the design of Vinko cabinet was to create a fine storage unit for clients who care about not only the quality of wine they drink, but also how it is stored, displayed and served. Vinko offers options for storing, cooling and even serving wine, other beverages and fine wine glasses on its shelves and inside its doors. The height of the cabinet also makes a perfect bar that can be used in homes, wine cellars, offices or hospitality establishments interested in creating a special corner for wine lovers. The

inside of the cabinet is customizable to fit other uses. The designer, Harri Koskinen, found a brilliant use for Zanat's signature carvings on a cabinet whose outer appearance communicates strength and simple Nordic elegance. The carvings between the front doors create a zipper-like seam, while the "shoehorn" carvings on the inside of the doors, not only look nice, but also stop wine glasses from sliding out when the door is moved. Standard version of the cabinet comes with an untypical wine-rack made of rounded beams in solid wood. Vinko is available in maple, ash, oak, cherry and walnut versions.



Wave Sideboard

Designed by Salih Teskeredzic

As a self-standing piece, the Wave is adapted to the concept of an open space residence, designed to serve as a cabinet, but also as a space-divider identified by its sculptural form as a spatial accent. It can be used as a dining room or living room sideboard, but also as a bedroom dresser.

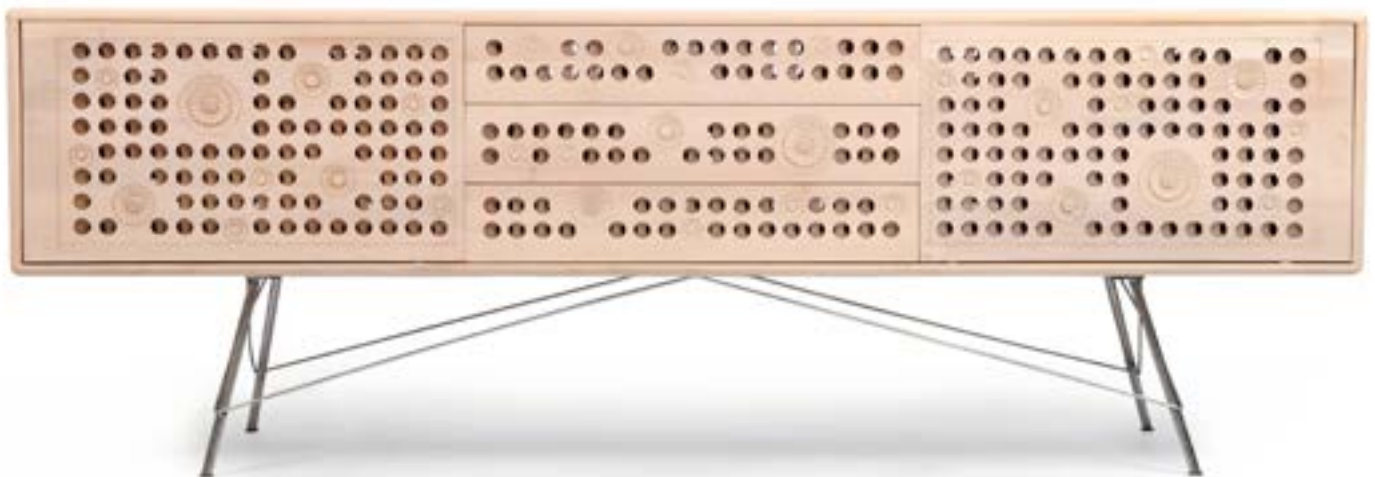







Branco Boxes

Designed by M onica Förster

Branco boxes come in three different sizes and several carving patterns. Design inspiration comes from sculptures created by Constantin Brancusi, one of the fathers of modernism, who was not only a sculptor, painter and photographer, but also a woodcarver. These hand-carved decorative boxes, crafted in solid maple, are also extraordinarily versatile and can be used as storage boxes on open shelves, as side tables, combined into a coffee table, stacked on top of each other as a sculptural element. How to combine and use them is up to one's imagination.





Nera Bowls

Designed by Monica Förster

Nera bowls, designed by Monica Förster, combine light wooden bowls, which seem to levitate on hand-carved stands. The bowls come in three different sizes and are available in three different species of wood. They come with different carving patterns, which add a special playful expression to the bowls.







Nur mirror

Designed by Monica Förster

As the light (i.e. nur) reflects in a mirror, one's beauty it shows and in beautifying it aids.

Mirror is an object in the service of beauty and beautiful it should be. Nur table mirror is charming and beautiful. The mirror with a handle rests unattached in a hand-carved cone so it can be taken out and moved. Nur likes to wear only black and is dressed in different hand-carved lace.

Nur mirror is the winner of Elle Decoration Swedish Design Awards 2018 for Best Interior detail.



Stopme bookstop/doorstop

Designed by Monica Förster

Stopme bookstop/doorstop is a cute decorative object with a hand-carved cone base and skillfully stitched handle in leather. It can be used as a decorative object on a shelf, but it was also designed with a function in mind: to stop a stack of books from falling or stop an open door from closing. Other functions are up to the creativity of users.





Touch Trays

Designed by Studioilse

Touch Trays are a part of the Touch collection consisting of benches, trays and other objects. Their special quality lies in the handcarved surfaces that engage our instinctive impulse to feel something, and reflect our hunger for more tactile surroundings in the digital age. The trays are hand-made in Bosnia Herzegovina using Zanat's wood carving skills, current nominee for the UNESCO Intangible Cultural Heritage of Humanity List. Since the craftsmen carve the trays at random, without drawings – each is unique as no two carved surfaces will ever look the same.







Touch Lamps

Designed by Studioilse

Touch lamps are a part of the Touch collection designed by Studioilse. Their special quality lies in the hand-carved surfaces that engage our instinctive impulse to feel something, and reflect our hunger for more tactile surroundings in the digital age. Touch lamps consist of a hand-carved base in turned solid wood and a hand-made lamp shade featuring fine linen fabric on the outside.



DESIGNERS

Behind every beautiful object there is a brilliant idea; behind every brilliant idea there is a source of inspiration. Brilliant ideas come from brilliant people. Inspiration can come from a multitude of sources. In Zanat, we see it our role not only to invite brilliant designers to work with us, but also to provide a source of inspiration. The passion we have for our craft, the thrill we have for trying new ideas, the ideals behind what we do and the friendliness with which we approach those we work with have never failed to be a great source of inspiration.



Monica Förster

Born in 1966, Monica Förster is the creator of some of the most internationally renowned objects in contemporary Swedish design today. Her work is characterized by a strong sense of pure form mixed with a never-ending curiosity for new materials and technology. Always trying to work in a cross-disciplinary way, she invents and renews typologies in industrial, furniture and object design.

Monica Förster, who is one of the top names within Swedish design, has created some of the future's classic designs. Monica Förster Design Studio is based in Stockholm, and works on an international level with companies such as Alessi, Cappellini, Poltrona Frau, De Padova, Bernhardt, Volvo, Whirlpool, Vibia, Tacchini, Modus, Offecct and Swedese.

She has been awarded numerous Swedish and international awards such as Designer of the Year and has been exhibited all over the world in museums and institutions such as MoMA, New York and VA museum, London. Monica Förster has also been represented in the International Design Yearbook.



Sara Helder

Sara Helder graduated as an interior architect SIR/MSA, 1997 at HDK in Gothenburgh. Sara is together with Gert Wingårdh responsible for the interior design of the Swedish Embassy in Washington DC, Aula Medica at Karolinska Institutet and recently opened Hotel Miss Clara (on Wallpapers to watch list).



Harri Koskinen

Harri Koskinen (born in 1970) has an uncompromising, bold design aesthetic that has gained him international renown since the early days of his career. Practicality, a spare style and a conceptual approach to product and spatial design are Koskinen's trademarks. His clients include Alessi, Arabia, Artek, Cassina IXC, Design House Stockholm, Finlandia Vodka Worldwide, Genelec, Iittala, Issey Miyake Inc., Montana, Muji, Panasonic, Seiko Instruments Inc., Swarovski, Venini and Woodnotes.

Founded in 2000, Koskinen's design agency Friends of Industry Ltd. is involved in product, concept and exhibition design. In 2009, Koskinen launched his first namesake collection, Harri Koskinen Works, consisting of furniture and a lamp. That same year, he became a partner in the Finnish organic and local production food concept and store called Maatilatori – Eat & Joy Farmers Market. In January 2012 Koskinen was appointed Design Director of the Iittala brand.

Koskinen's works have been on display in exhibitions around the world. He has been awarded several major design prizes, such as the Kaj Franck Design Prize (2014), the Torsten and Wanja Söderberg Prize (2009), the Pro Finlandia Medal (2007) and the Compasso d'Oro prize (2004).



Jasna Mujkic

Born in 1972, Jasna Mujkic teaches product design courses at the Arts Academy in Sarajevo. In addition to her teaching career, Jasna is an active product designer, with a special interest in furniture design. She is the author of an official arts textbook used in Bosnian public schools. Her designs have been exhibited in a number of international design exhibitions. Jasna was the first designer who collaborated with Zanat (then Rukotvorine) on the modernization of its hand-carved motifs and their application to products of modern design (e.g. Quiet chair and stool). Jasna's Ombra coffee table (designed for Zanat) is the winner of the Interior Innovation Award – IMM 2012.



Ludovica + Roberto Palomba

Ludovica + Roberto Palomba have been designing for over 25 years products and spaces that escape trends. Their approach is to search for essence in every project, closer to the concept of balance of oriental heritage rather than to the nordic style. The goal of their work is not only an aesthetic result but positive impact on well-being. As Ludovica and Roberto Palomba note: "It would be easier for us to use decorations and figures of speech than to investigate politeness." Thanks to their foresight and unrelenting curiosity, their work has influenced many creative fields such as architecture and interior design, yacht design and product design.

They collaborate and art direct some of the most renown international design brands and have received numerous international awards and recognitions such as Compasso D'Oro, Elle Decoration International Design Award, Red Dot, Design Plus, Good Design Award and German Design Award.



Studioilse

Studioilse, led by Ilse Crawford and Oscar Peña, is a multi-disciplinary design studio with a simple mission to put human needs and desires at the centre of all that they do. This means creating environments where humans feel comfortable; public spaces that make people feel at home and homes that are habitable and make sense for the people who live in them. It means designing furniture and products that support and enhance human behaviour and actions in everyday life.



Salih Teskeredzic

Salih Teskeredzic is the most influential and most prolific product designer in Bosnia. Born in 1962, Salih is a tenured professor of product design at the Sarajevo Arts Academy and a co-founder of the designer furniture brand Gazzda. He founded and managed an independent architecture and design studio in Vienna (2000–2004) and in 2007 he launched a Sarajevo based architecture and design studio AD ARTE. Salih is known for pushing the technological limits of modern furniture design in wood (his favorite material), for emotionally expressive and irresistibly elegant pieces of furniture. His earlier work earned him numerous design awards in the former Yugoslavia. In recent years, Salih has been received four Red Dot awards and as many as ten Interior Innovation Awards granted by the German Design Council.



Gert Wingårdh

Gert Wingårdh graduated as an architect SAR/MSA, 1975 at Chalmers University of Technology in Gothenburgh. Gert founded Wingårdhs in 1977 which today employs more than 150 people. The office pays great attention to details and the projects span every aspect from the urban scale to the private space. Notable projects are the Swedish Embassies in Berlin and Washington DC, Aula Medica at Karolinska Institutet in Stockholm and the restoration of the National Museum in Stockholm.

Gert Wingårdh has continually participated in numerous architectural competitions and has an excellent track record with more than 70 wins, most recently for Statoil HQ, Stavanger, Norway and Liljewalchs Art Museum in Stockholm, Sweden. Buildings designed by Gert Wingårdh are frequently nominated to the European Mies van der Rohe Awards, have received awards by America Institute of Architects and is the recipient of the highest Swedish Architectural award (the Kasper Salin Prize) a unique five times.



MATERIALS & FINISHES
SAMPLE CARVING TEXTURES

MATERIALS &
FINISHES



Ash Oil



Ash White Oil



Maple Black Stain



Maple Wenge Stain



Maple White Oil



Oak Oil



Oak White Oil



Steamed Walnut Oil



Uncoated Saddle Leather



Soft Black Leather



Soft Brown Leather

SAMPLE
CARVING TEXTURES



Diamonds



Cane



Reshma S



Reshma Roof Tiles



Reshma A



Wood Grains



Warm Holes



Sand



Linea



Ornamental



Touch



Cuts



Dama



Your own custom designed



**TECHNICAL INFORMATION
ON PRODUCTS**

TABLES

Unna Fixed Table

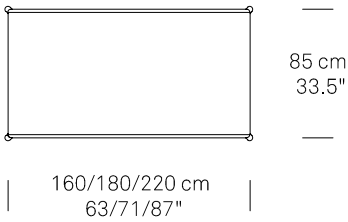
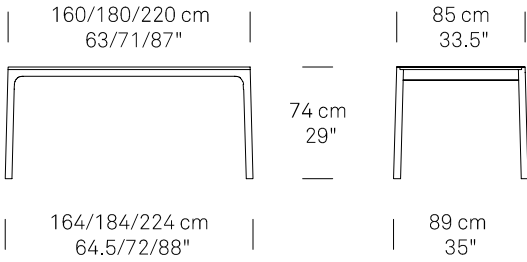

Unna Extendible Table

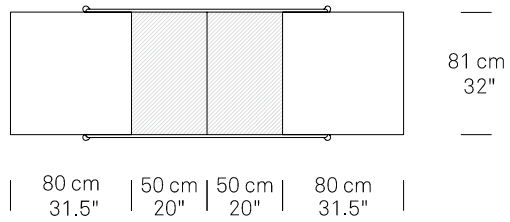
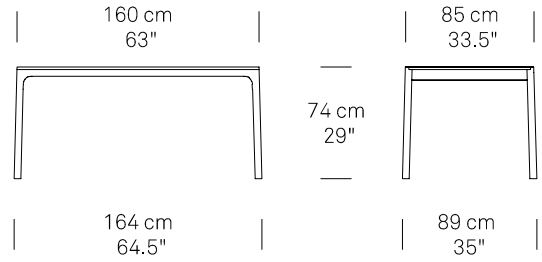

Touch Table

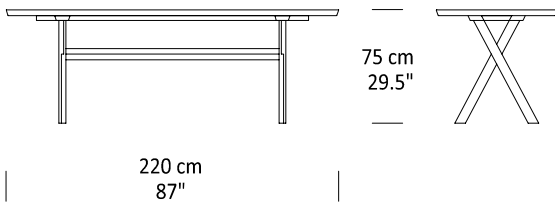

Neron Table

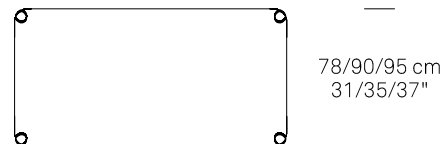
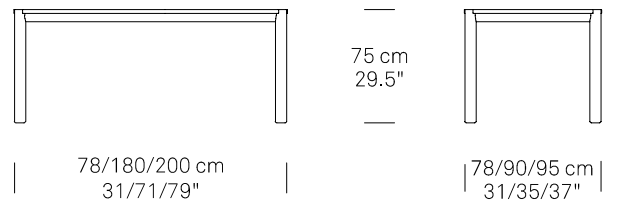

Neron 78 Table

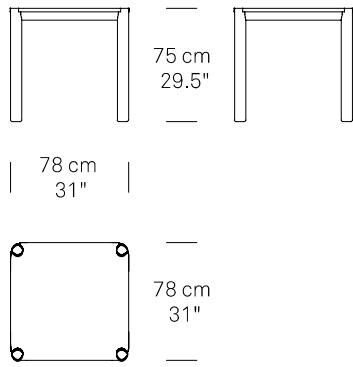

Branchmark (3) Table

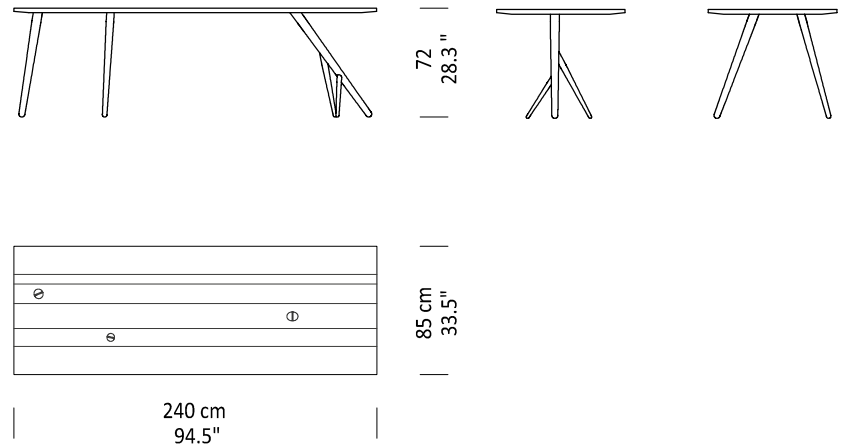

Branchmark (8) Table

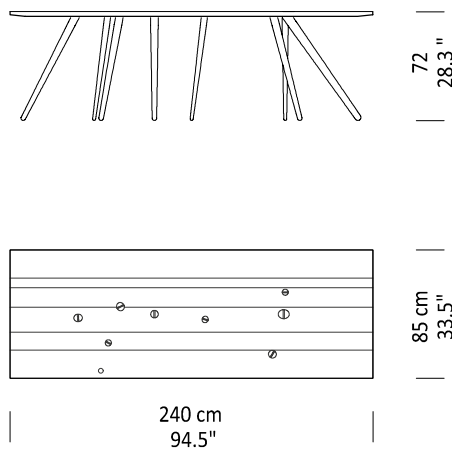

Branchmark (4) Table

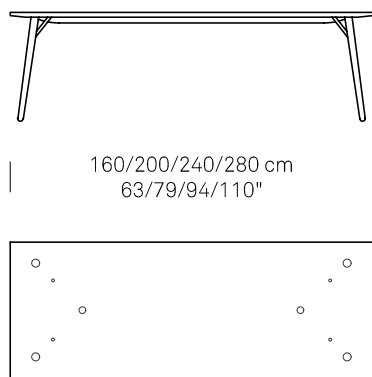

Branchmark (o) Table

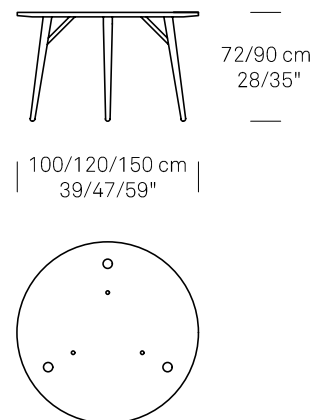

Daisy Table Wooden Legs

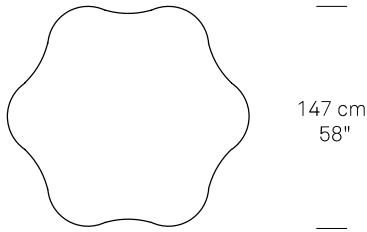
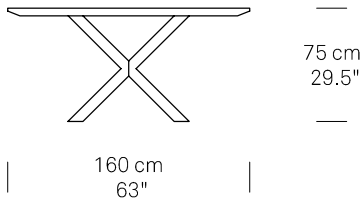

Daisy Table Stainless Steel Legs

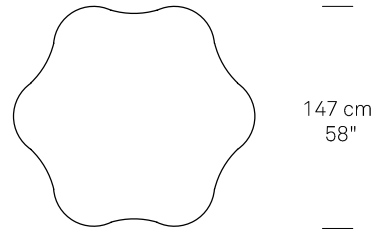
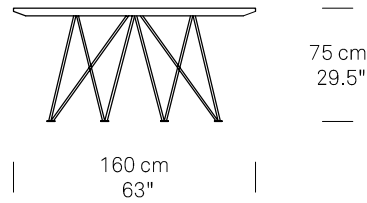

Wave Table

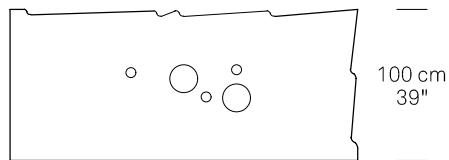
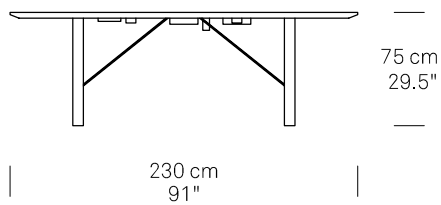

Touch Console

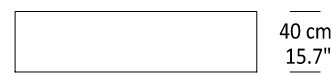
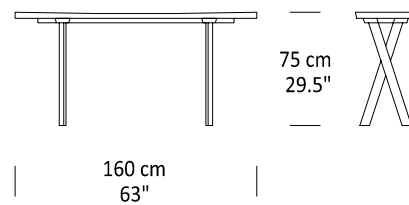

Nera Table Large

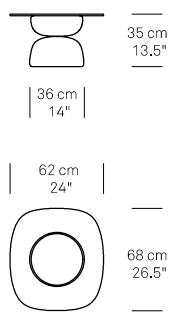

Nera Table Small

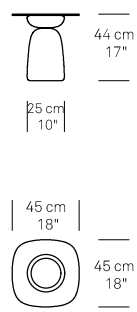

Bowlkan Table Large

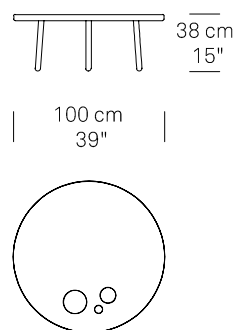

Bowlkan Table Small

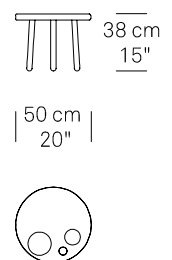

Ombra Table Large

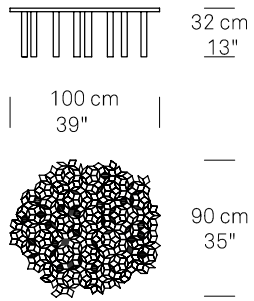

Ombra Table Small

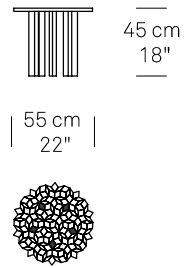

Daisy Side Table Wood Legs

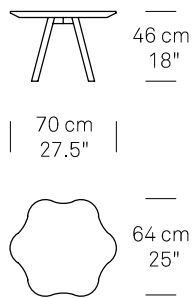

Daisy Side Table Stainless Steel Legs

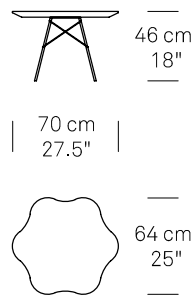

CHAIRS & STOOLS

Sana Dining Chair

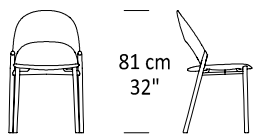

81 cm
32"

49 cm
19.4"

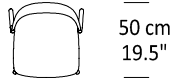

50 cm
19.5"

Igman Chair with Armrests

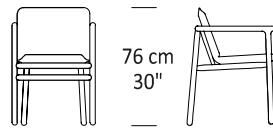

76 cm
30"

55 cm
21.5"

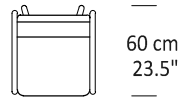

60 cm
23.5"

Igman Chair without Armrests

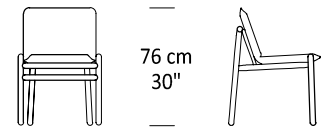

76 cm
30"

55 cm
21.5"



60 cm
23.5"

Unna Chair

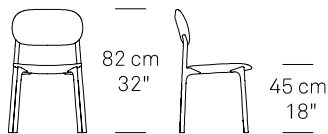

82 cm
32"

45 cm
18"

52 cm
20.5"

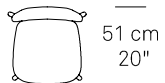

51 cm
20"

Se_Go Chair Wood Legs

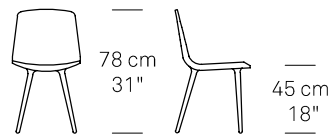

78 cm
31"

45 cm
18"

45 cm
18"



52 cm
20.5"

Se_Go Chair Stainless Steel Legs



78 cm
31"

45 cm
18"

45 cm
18"



52 cm
20.5"

Quiet Chair

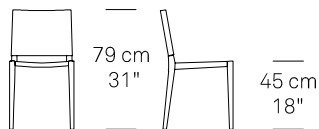

79 cm
31"

45 cm
18"

42 cm
17"



47 cm
18.5"

Dama Lounge Chair

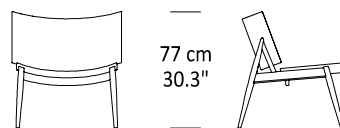

77 cm
30.3"

72 cm
28.5"

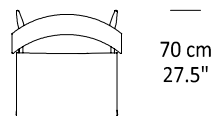

70 cm
27.5"

Unna Lounge Chair

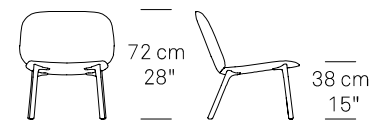

72 cm
28"

38 cm
15"

62 cm
24"

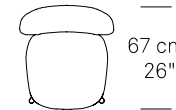

67 cm
26"

Igman Lounge Chair

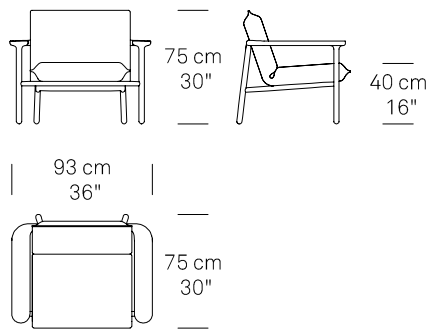

Igman Ottoman

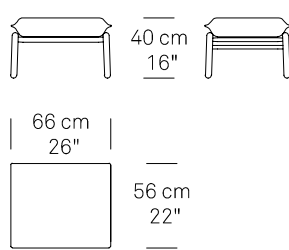

Touch Bench 45 Wood Legs

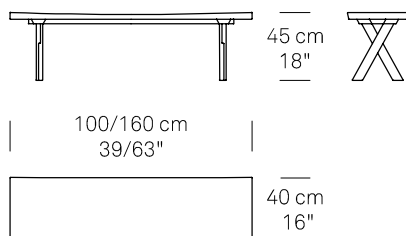

Touch Bench 32 Wood Legs

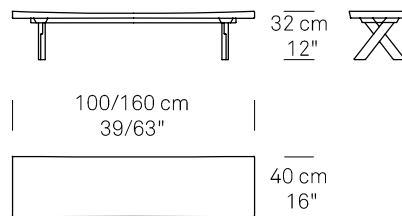

Touch Bench 45 Bronze Legs

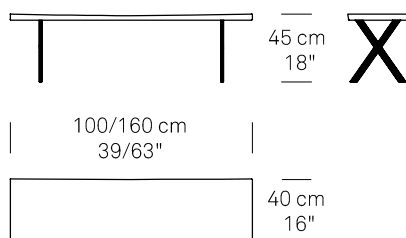

Touch Bench 32 Bronze Legs

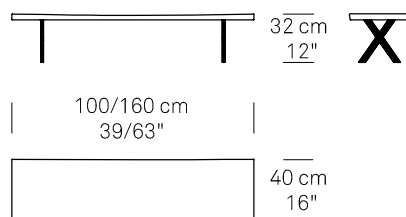

Touch Bench w Backrest Wood Legs only

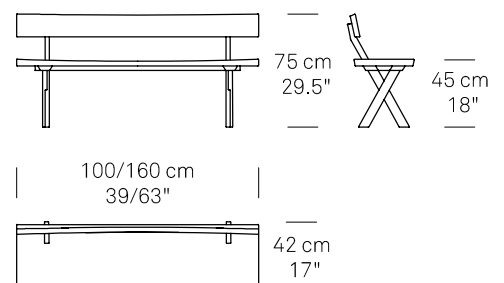

Nera Stool

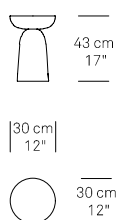

Touch Stool Halfmoon

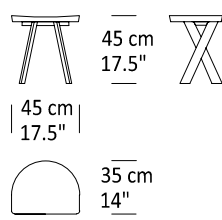

Touch Stool Pill

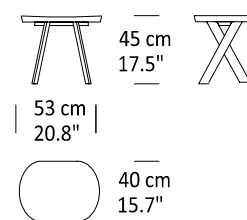

Tattoo Stool

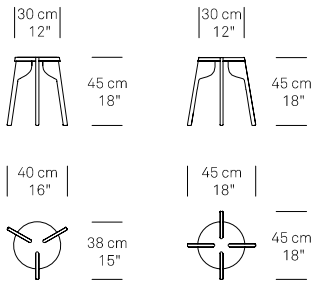

Tattoo Bar Stool Plain

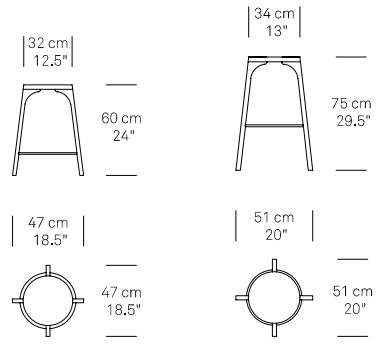

Tattoo Bar Stool Carved

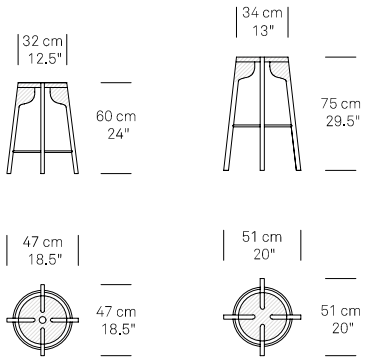

Quiet Stool

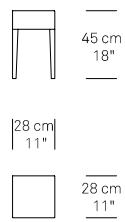

STORAGE

Touch Sideboard high w. 4 doors

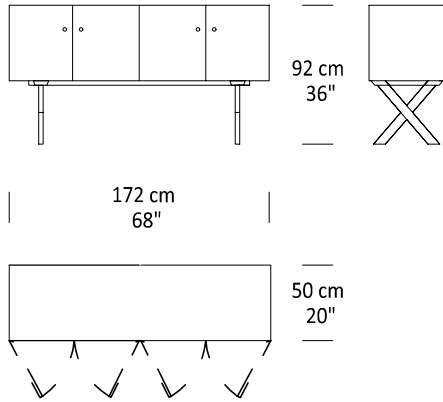

Touch Sideboard high w. 3 doors

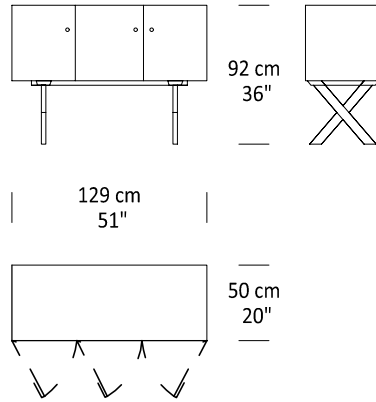

Touch Sideboard low w. 4 doors

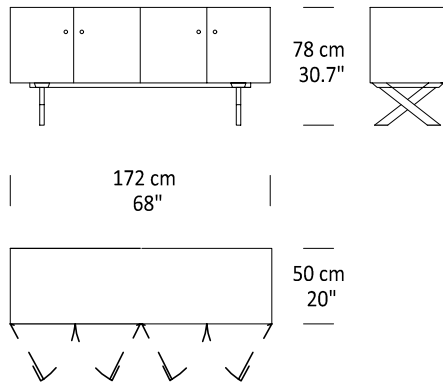

Touch Sideboard low w. 3 doors

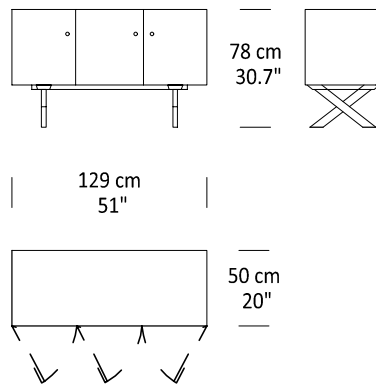

Tara Shelves Large

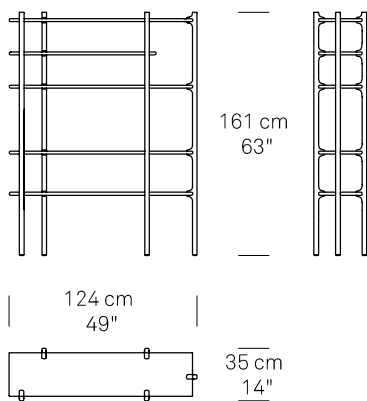

Tara Shelves Small

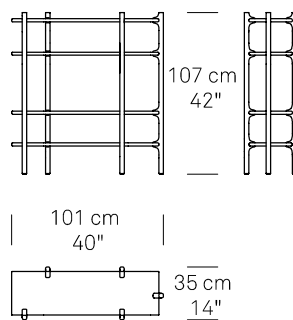

Tara System Building Principles

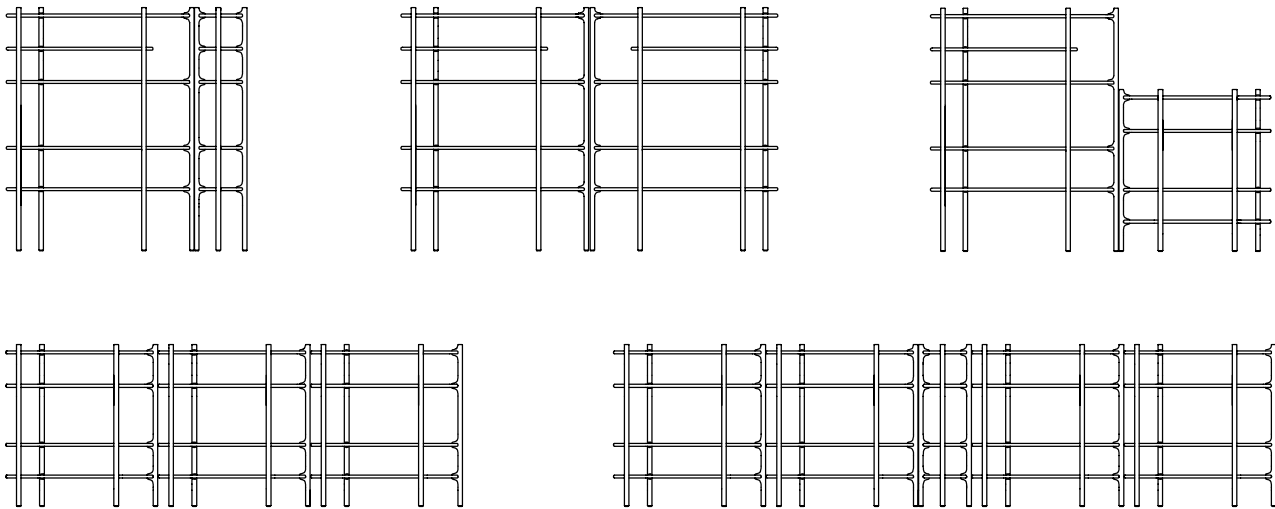

Vinko Wine Cabinet

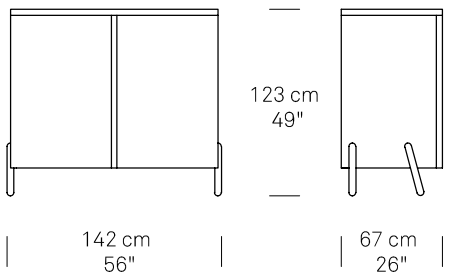

Wave Sideboard

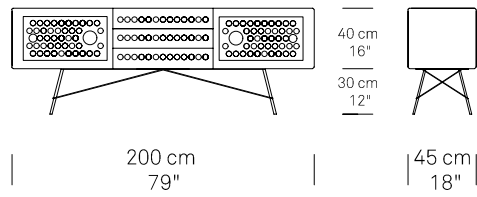

ACCESSORIES

Branco Boxes

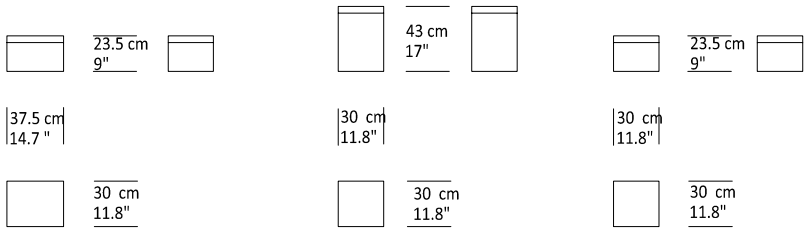





Kalia Chaise Longue & Koba Side Tables
Jean-Marie Massaud



Koba Side Tables
Jean-Marie Massaud



Koam Sideboard
Jean-Marie Massaud



Piano Coffee and Side Tables
Ludovica + Roberto Palomba





Unna Console
Monica Förster



Scentainers (fragrance containers)
Monica Förster



Hide & Seek Containers and Coffee/Side Tables
Monica Förster



Café Tattoo Chair
Gert Wingårdh & Sara Helder



IMPROVE YOUR HOME & IMPROVE OUR WORLD

ZANAT

www.zanat.org | info@zanat.org | t: +387 36 727 299